



MAMS Presentation



Microgravity Acceleration Measurement System (MAMS) ISS Flight Configuration Description

Presentation to Microgravity Environment Interpretation Tutorial
Cleveland, OH 6 March, 2001

By: **James C. Fox**
MAMS Program Manager
Canopus Systems Inc.



MAMS Mission



- **The mission of the Microgravity Acceleration Measurement System (MAMS) is to measure and report vibratory (>1Hz) and quasi-steady acceleration (<1Hz) within the United States Laboratory Module on the International Space Station.**
- **MAMS acceleration data will be utilized in the following scientific investigations:**
 - **Microgravity Environment Verification**
 - **Low-Frequency Vehicle Dynamics Analysis**
 - **Combustion, Fluid Physics and Materials Microgravity Science Experiments**
 - **Attitude Control System Analysis**
 - **Atmospheric Drag Estimation**



MAMS VS. OARE DIFFERENCES

- **The MAMS Quasi-steady acceleration measurement utilizes the same OARE Sensor Subsystem except Y/Z axes bandwidths are 1.0 Hz. in MAMS**
- **MAMS does not provide for on-orbit scale factor calibration since OARE measurements verified a stable scale factor over many missions**
- **MAMS utilizes a simplified Bias Calibration Table Assembly (BCTA) however the bias data measurement is conducted in the same manner as OARE**
- **MAMS does not provide for in situ storage of Trimmed Mean Filtered bias calibration data. Instead, ground processing of bias calibration data is planned**



ISS Microgravity Acceleration Measurement System (MAMS) Functional Requirements



MAMS Shall Measure:

- **Unisolated vibratory and quasi-steady accelerations at its installed EXPRESS Rack location within the US Laboratory module**
- **Quasi-steady accelerations in three orthogonal MESA sensor input axes, with an accuracy and resolution of 100 nano-g or better from the orbital rate to 1.0 Hz**
- **Vibratory accelerations in three orthogonal HIRAP sensing input axes, with an accuracy and resolution of 1/10th of the magnitude or one microgravity, whichever is greater, of the Space Station system acceleration limits from 0.01 to 100 Hz**
- **MAMS shall make available, when commanded, the vibratory and quasi-steady acceleration environment measurements to the Rack Interface Controller (RIC) along with the required Health and Status data**

MAMS Lower Subplate Assembly (OG 0°, IG 90°)





MAMS DMDL ENCLOSURE REAR VIEW



6 March 2001

Canopus Systems Inc.

MEIT-2001 / Section 5 / Page 6



MAMS Operational Features

- Enclosure** : DMDL, 21.86”H x 18.37”W x 23.55”D
- Weight** : 117 lb.
- Installation** : EXPRESS Rack #1 for ISS Flight 6.A
- Power Interface** : 28 VDC supply from ER#1 Power Panel, 79.0 ± 1.0 watts, nominal
- Data Interface** : Ethernet link to ER#1 Control Panel (Rack Interface Controller)
- Power Up** : Enabled by RIC Software Controller after crew sets panel power switch to “ON” (no other crew time requirement)

- Thermal Control** : Avionics Air Assembly cooling with internal circulating fan
- Launch Status** : Launched unpowered in ER#1 in MPLM



MAMS Calibrated Data Performance Requirements



Quasi-Steady Data (OSS MESA)	Parameters	
	X-axis	Y, Z Axes
C Range Resolution	3.05 nano-g	4.6 nano-g
C Range Accuracy	± 100 nano-g	± 100 nano-g
C Range Full Scale	± 100 micro-g	± 150 micro-g
B Range Full Scale	± 1.0 milli-g	± 1.97 milli-g
A Range Full Scale	+ 10 milli-g	+ 25 milli-g
Pre-Sample Filter Bandwidth	10 ⁻⁵ to 1.0 Hz	
Maximum Data Rate	1.0 Kbps	
Input Axis Alignment to Reference	± 20 arc minutes	
IA Positioning Accuracy	5 arc minutes	
Bias Temperature Coefficient	0.05 µg/°C	
Vibratory Data (HIRAP)		
Resolution and Accuracy (DSP output)	± 1.0 micro-g (± 10 ⁻⁶ g)	
Full Scale Dynamic Range	± 16 milli-g (± 16x10 ⁻³ g)	
Pre-Sample Filter Bandwidth	10 ⁻⁴ to 100 Hz	
Maximum Data Rate	52 Kbps	
Input Axis Alignment to Reference	± 10 arc minutes	
Bias Temperature Coefficient (Max)	10 µg/°C	



MAMS MESA Calibration Features

- **Scale Factor calibration performed pre-launch with laser interferometer**
- **On-orbit triaxial bias calibration data collected periodically via commanded parameters:**
 - **Interval between calibrations selectable from 0.5 to 273 hours (default 1.0 hour)**
 - **Number of sensor F.S. ranges to be calibrated (1, 2 or 3)**
- **Each range calibration requires approx. 6.0 minutes**
- **Bias Calibration algorithms $\{f(t, T^\circ)\}$ developed retrospectively by the ground Telescience Center and corrections applied to stored sensor data samples for each sensor input axis**
- **Initial exploratory research period will be required to determine the extent of variation in the bias calibration algorithms for predicted ISS environmental conditions**
- **Verifiable long term stability of the Bias Calibration algorithms will provide opportunity to extend the bias calibration interval and thus increase continuous science data periods**
- **Variability in Bias Calibration data (and resultant data accuracy) will be mainly due to crew motion, mechanical pumps, fans and other exogenous (random) noise sources**



OSS Scale Factor vs. Operating Temperature (Nom. Oper. Temp 102°F)

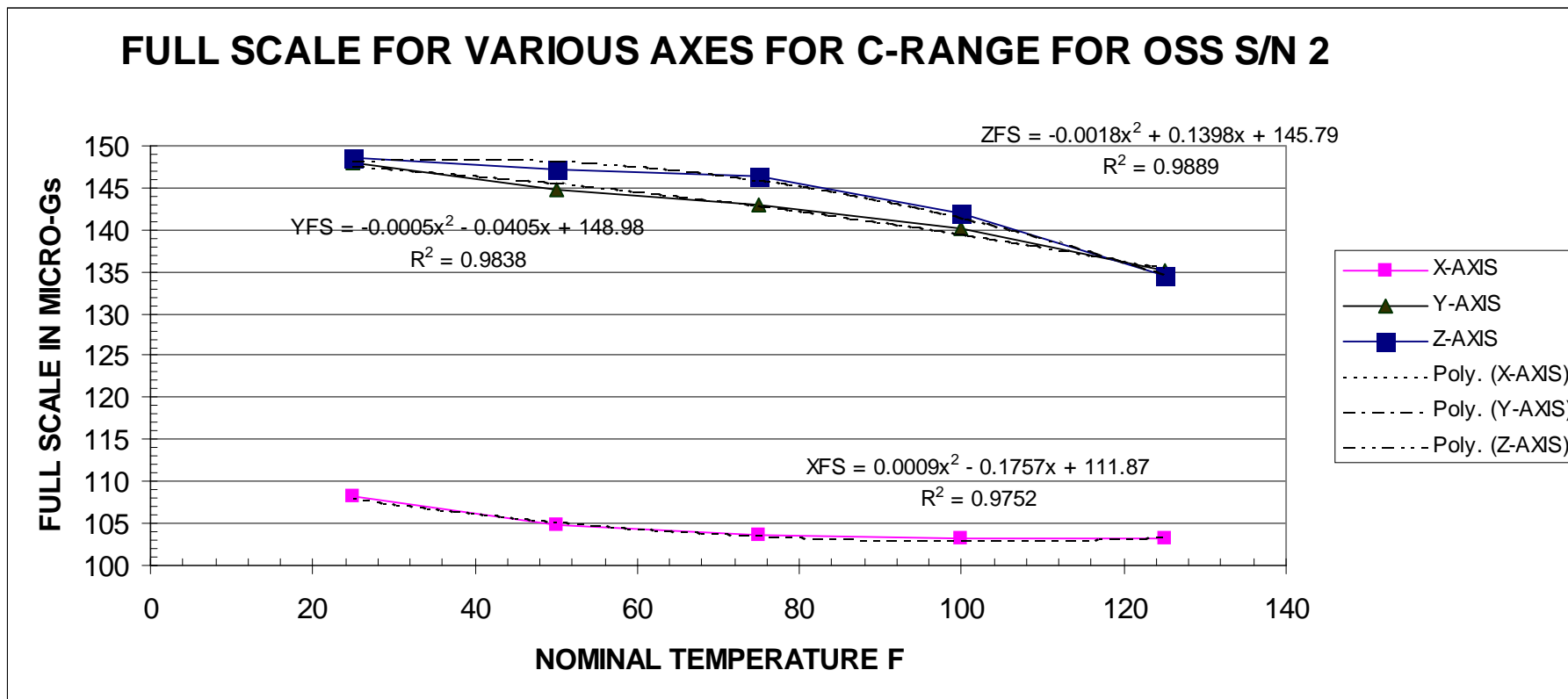



OSS ADC Noise Count Summary

MAMS System Noise Measurements			
Axis	ADC counts	ADC volts	Acceleration (A range)
OSS X	32763	-1.53mV	-1.53 μ g
OSS Y	32764	-1.22mV	-3.05 μ g
OSS Z	32764	-1.22mV	-3.05 μ g



High Resolution Accelerometer Package (HIRAP) provides wide bandwidth, high accuracy measurement data



6 March 2001

Canopus Systems Inc.

MEIT-2001 / Section 5 / Page 12



HIRAP Measured Sensor Calibration Data (per TP 400501)



<u>Axis</u>	<u>Resolution</u>	<u>Scale Factor</u>	<u>Bias</u>	<u>Sensor Output Bandwidth</u>	<u>Anti-Aliasing Butterworth Filter Bandwidth</u>	<u>Filter RMS Output Noise (Random)</u>
X	0.49 μg	-1.60167 $\frac{\text{milli-g}}{\text{volt}}$	-0.145 milli-g	159 Hz	100 Hz	113 μg
Y	0.49 μg	+1.5926 $\frac{\text{milli-g}}{\text{volt}}$	-0.639 milli-g	159 Hz	100 Hz	57 μg
Z	0.49 μg	-1.6080 $\frac{\text{milli-g}}{\text{volt}}$	-1.360 milli-g	159 Hz	100 Hz	85 μg



HIRAP ADC Noise Count Summary

MAMS System Noise Measurements			
Axis	ADC counts	ADC volts	Acceleration
HiRAP X	9	+2.7mV	+0.004mg
HiRAP Y	12 to 13	+3.7mV	+0.006mg
HiRAP Z	14 to 15	+4.3mV	+0.007mg



MAMS Operational Requirements

- **Nominal Unattended Operations with Minimal Ground Operator Intervention**
 - **Automatic startup when power is applied via the EXPRESS RIC**
 - System boots up and waits for TCP/IP Ethernet connection from the client
 - After socket connects, MAMS requests RIC time and initiates message and data transmission
 - **Nominal and Default operation control provided by adaptation parameters**
 - **Operator command override provided to modify operational modes**



MAMS Data Collection Rates

- **OARE Sensor Subsystem Acceleration Data**
 - 3 axes at 10 samples per second
- **HiRAP Acceleration Data**
 - 3 axes at 1000 samples per second
- **Payload Health and Status Data at 1 Hz**
- **General Housekeeping and Time Stamp Status sent at Science Data Rates**



MAMS Health and Status Message

The MAMS Health and Status Message (not including the **synch word**, nor the **EXPRESS Primary Header**).

Low Byte	High Byte
ECW Word (Reserved Word 1)	
Packet Count High Byte	Packet Count Low Byte
HiRAP X Temperature	HiRAP Y Temperature
HiRAP Z Temperature	BCTA Current
OSS Instrument Temperature High Byte	OSS Instrument Temp Low Byte
OSS Base Temperature High Byte	OSS Base Temperature Low Byte
MPCS1 Temperature High Byte	MPCS1 Temperature Low Byte
MOIS Temperature High Byte	MOIS Temperature Low Byte
Power Supply Temperature	System Current
Outer Gimbal Temperature	Front Panel Temperature



MAMS Command Types

	DATA TRANSMISSION COMMANDS		DATA THROTTLING COMMAND		FAN CONTROL COMMANDS
1a	Send Real-Time OSS Data to UOF	8	Set Maximum Data Transmission Rate from Stored Acceleration Buffer	20a	Turn Fan ON
1b	Do Not Send Real-Time OSS Data		BIAS CALIBRATION COMMANDS	20b	Turn Fan OFF
2a	Store Real-Time OSS Data			9	
2b	Do not Store Real-Time OSS Data		Reset NUMBER_BIAS_RANGES Parameter (This parameter controls the bias calibration sequence after one has been requested.)		
3a	Send Stored Real-Time OSS Data	10	Reset BIAS_PERIOD Parameter (in minutes) (This parameter controls when a bias calibration is scheduled)	21a	Move Inner Gimbal to Std. Pos.
3b	Stop Sending Stored Real-Time OSS Data		OSS DATA SELECTION COMMANDS	21b	Move Outer Gimbal to Opp. Pos.
4a	Send HiRAP Data	11a	Select OSS AFSD acceleration data for use	21c	Move Inner Gimbal to Opp. Pos.
4b	Do Not Send HiRAP Data	11b	Select OSS Raw (unfiltered) acceleration data for use.	21d	Move Outer Gimbal to Std. Pos.
5	Reset Status_Housekeeping_Period. (in minutes) (This parameter controls when a Status/Housekeeping Packet (SHP) is sent as Backup)	12	Set Minimum OSS Range (Axis, Range)		
6	Set Error/Status (Text Message) Transmission State (on/off and level); Messages will not be buffered if not sent.		GLOBAL RESET COMMAND	22	Create New Adaptation Parameter File
7	Send Adaptation Parameter List	13	Reset MPCS		



Additional MAMS Functions



- **Ethernet connection/reconnection**
- **Time Stamping**
- **OSS ranging on each accelerometer axis**
- **Proofmass capture in event of Loss of constraintment**
- **Bias Calibration and Bias Calibration Table Control (Includes Backup BCTA Control Mode via Adaptation Parameter)**
- **Message Formatting**

MAMS Installed in ER #1



6 March 2001

Canopus Systems Inc.

MEIT-2001 / Section 5 / Page 20



APPENDIX TO MAMS PRESENTATION



- 1. MAMS Functional Block Diagram**
- 2. MAMS Data Path Block Diagram**
- 3. MAMS Upper Subplate Assembly**
- 4. Spare OSS LRU**
- 5. OSS S/N 02 Bias Measurements**
- 6. OSS X-Axis Sensor Misalignment Check**
- 7. X Axes Acceleration Count Histogram, BCTA @ 180°, 0°**
- 8. X Axes Acceleration Count Histogram, BCTA @ 0°, 0°**
- 9. MAMS Messages and Telemetry Data Type Definitions**
- 10. MAMS Flight Configuration**
- 11. MAMS Design/Development Team**



MAMS Functional Block Diagram

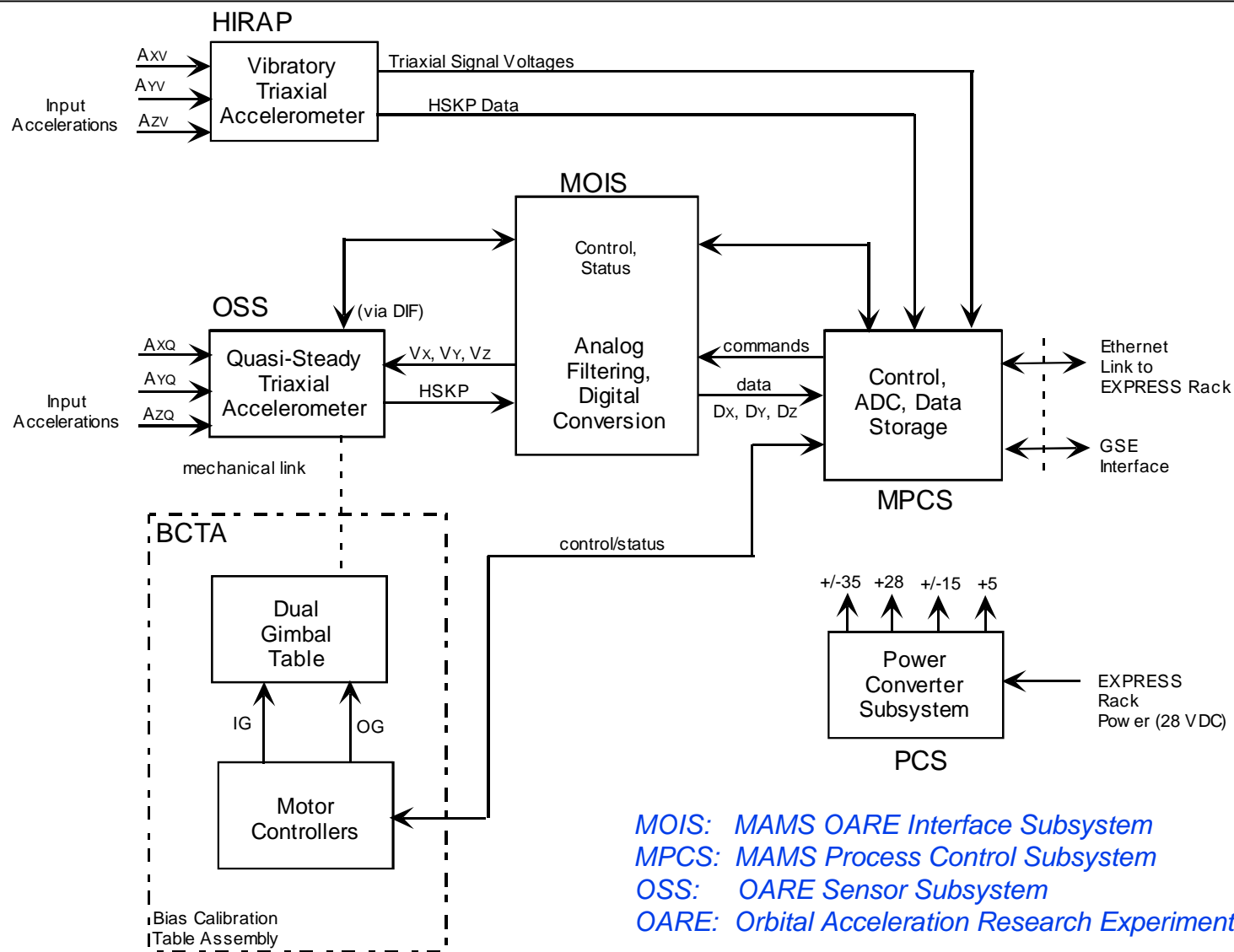

6 March 2001

Canopus Systems Inc.

MEIT-2001 / Section 5 / Page A.1



MAMS Data Path Block Diagram

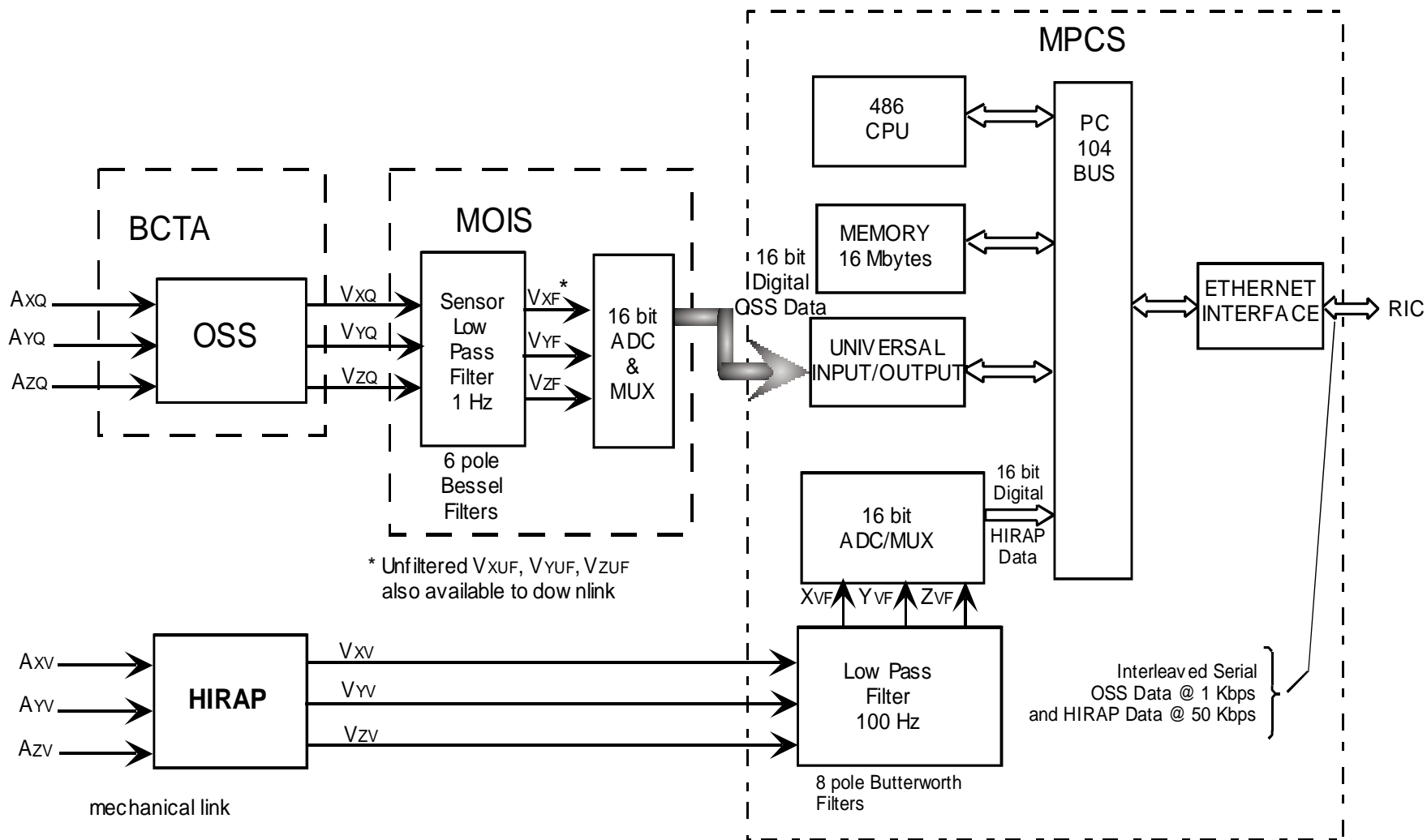

MAMS Upper Subplate Assembly



6 March 2001

Canopus Systems Inc.

MEIT-2001 / Section 5 / Page A.3

Spare OSS LRU

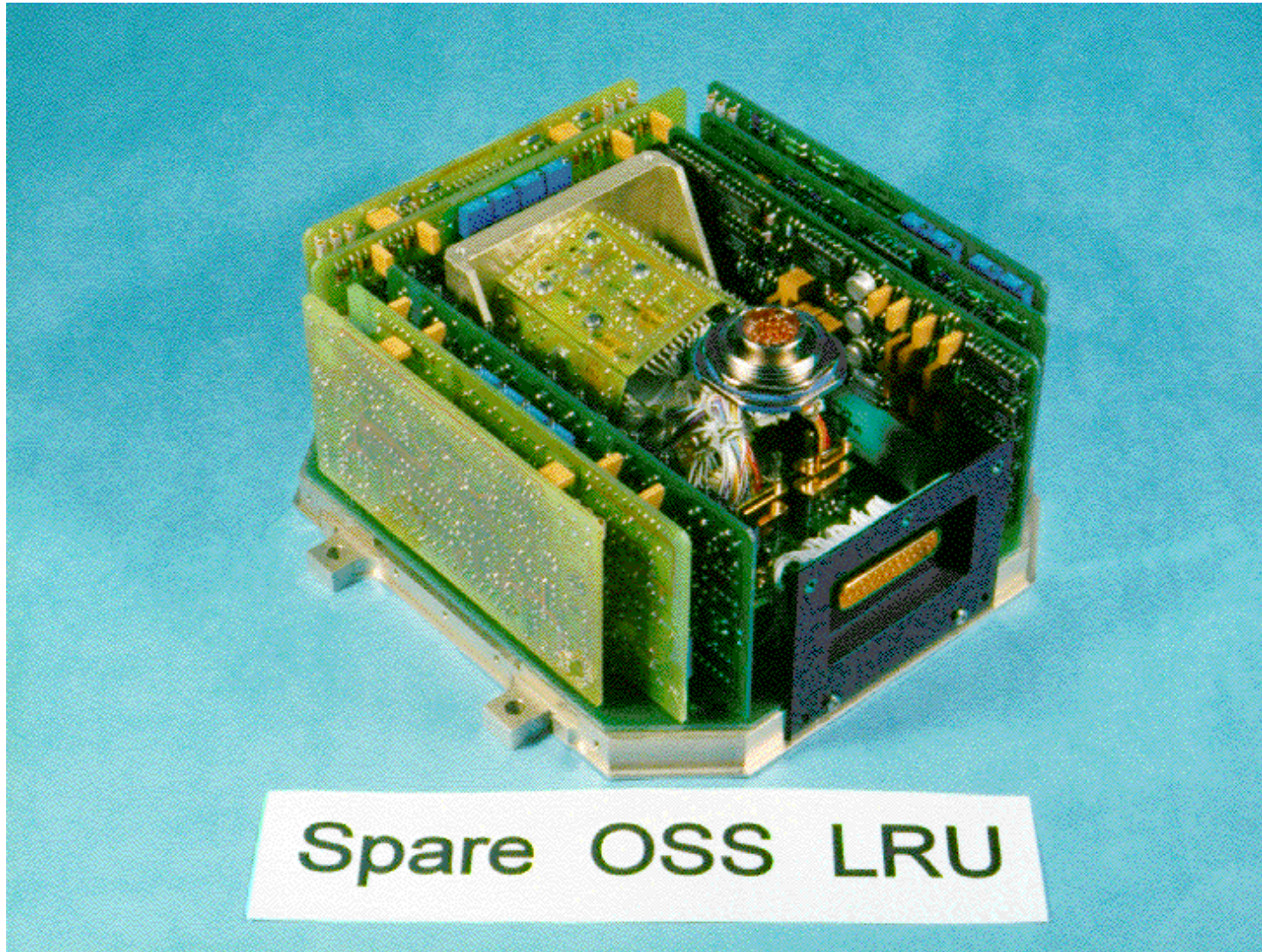



OSS S/N 02 Bias Measurements

*Bias Data Measurements in μg at ambient temperature
on Leitz Dividing Head*

Date:	9/96	7/99	8/99
X_A	+41	+12.5	+18.5
X_B	+39		
X_C	+39		
Y_A	-49	58	+5
Y_B	+175		
Y_C	+144		
Z_A	+154	-192	-207
Z_B	+12		
Z_C	+18		



OSS Cylindrical (X Axis) Sensor Misalignment Error Check

Mechanical Misalignment Error Sources

- X Input Axis Angle w.r. to OSS Base 2.3 arc minutes (measured)
- OSS Base to BCTA Base (Gimbal Skew Tolerance) 5.0 arc min.
- BCTA Base to DMDL Base (Subplate Flatness Spec) 5.9 arc min
 - Allowable RSS Mechanical Error 7.9 arc min.
- RSS Mechanical Error Limit in 1 G Field ($290 \mu\text{g}/\text{arc min}$) = $2290 \mu\text{g}$
- **Spot Check: 180° Rotation of X Axis with Leveled DMDL Base = $1200 \mu\text{g}$ Output Change**
- **Gimbal Rotation Position Check Measurements**
 - OG Rotation to Hard Stop @ 273,850 microsteps (42,785 encoder cts.) = 180.027 deg.
 - IG Rotation to Hard Stop @ 71,234 microsteps (11,118 encoder cts.) = 89.999 deg.
- **Data Histograms Summary:**
 1. X Axis Mean Acceleration, BCTA @ $0^\circ, 0^\circ$: $-3 \mu\text{g}$
 2. X Axis Mean Acceleration, BCTA @ $180^\circ, 0^\circ$: $1197 \mu\text{g}$
 3. X Axis Mean Acceleration, BCTA @ $180^\circ, 90^\circ$: $1122 \mu\text{g}$

$\Delta \text{O/P} = 1200 \mu\text{g}$



X Axis Acceleration Count Histogram, BCTA at 180°, 0°

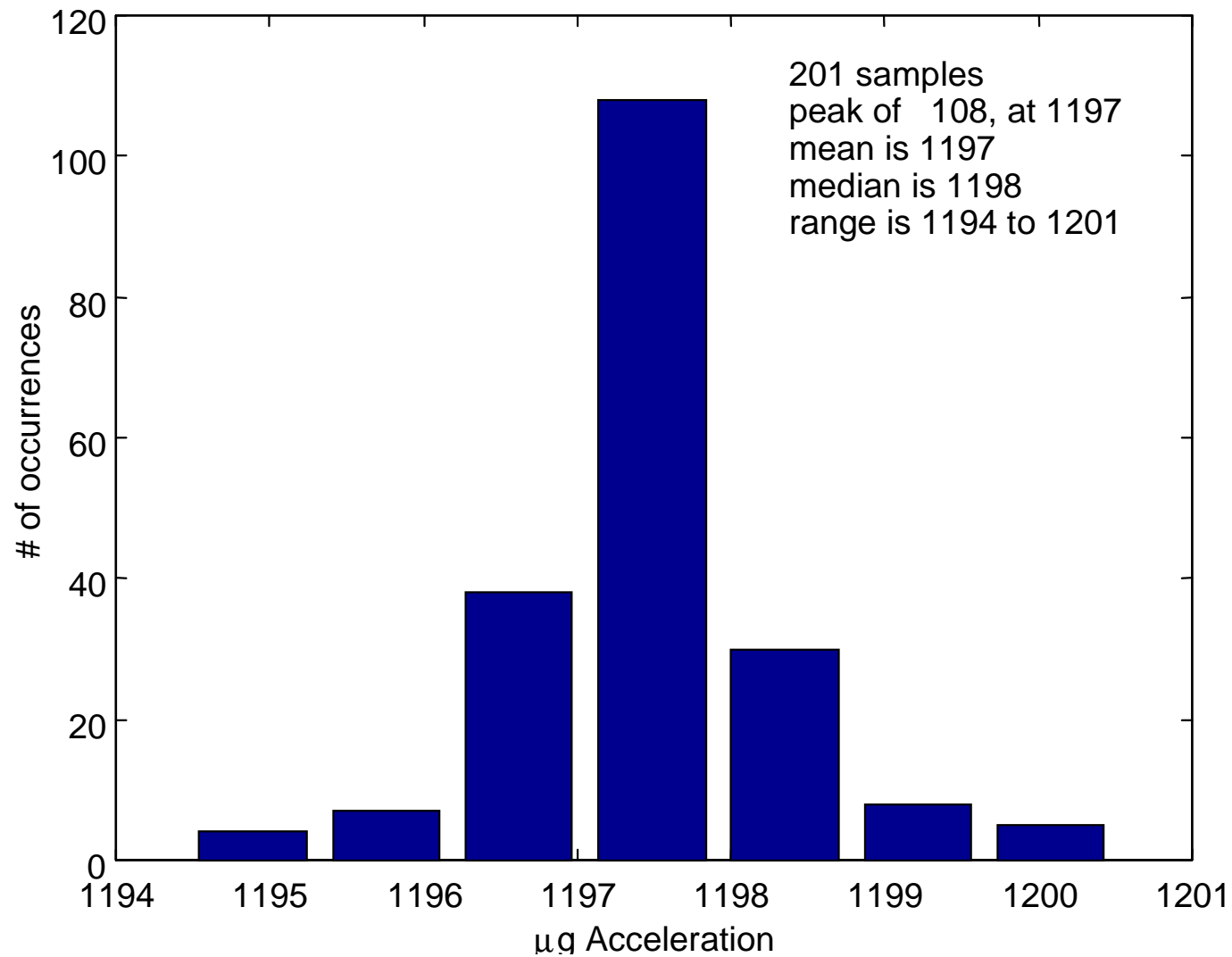



X Axis Acceleration Count Histogram, BCTA at 0°, 0°

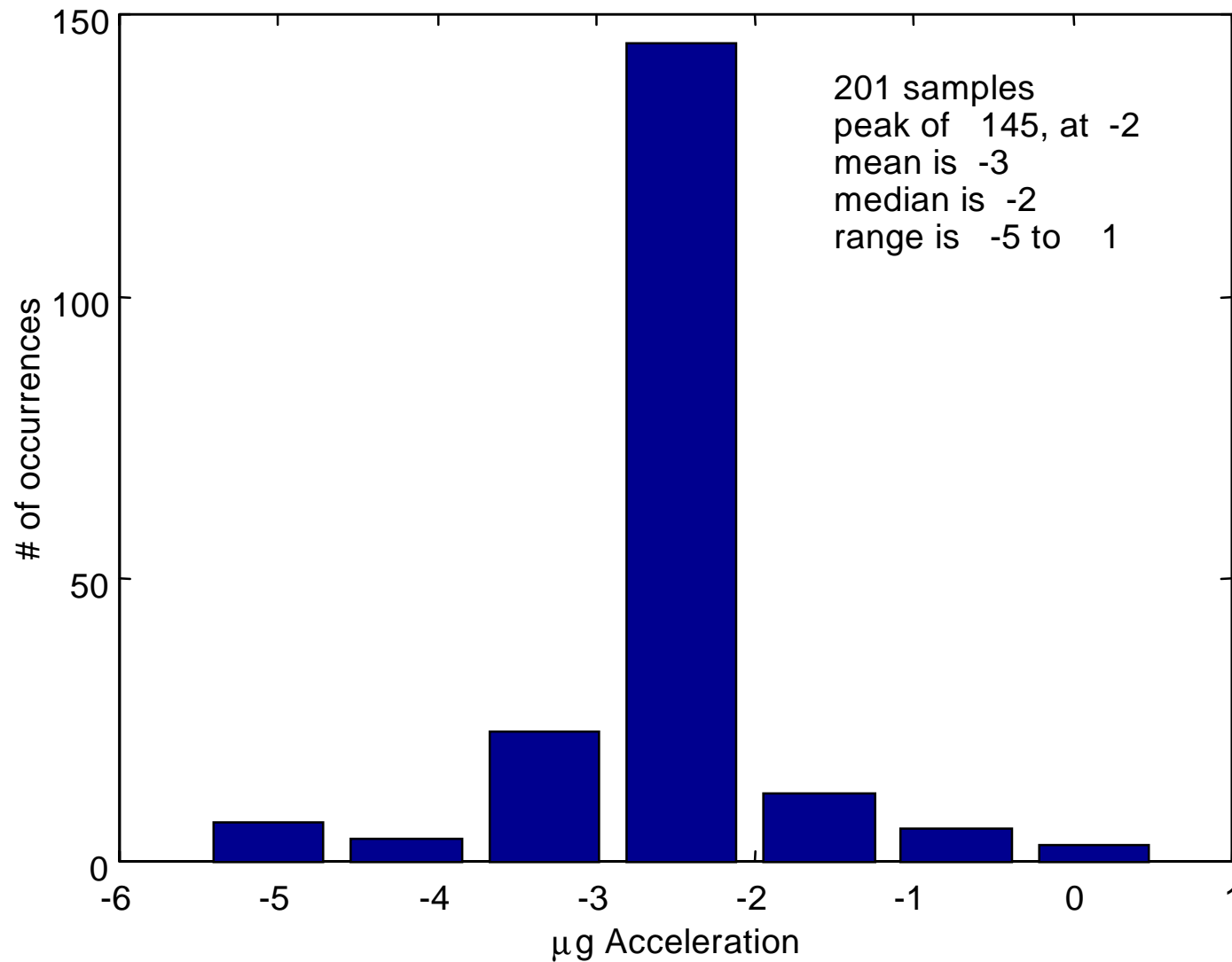



AMS Messages and Telemetry Data Type Definitions



MAMS Message Type	Description and EXPRESS Secondary Header Telemetry Data Type	Approximate Required Ethernet Trans. Rate including ER headers (bits per second)
1. Payload Health/Status Message to ISS	Required MAMS Health and Status Message sent every second. None.	304 bps, sent every second
2. Error & State Message (Text Message)	Text Messages which describe command responses, operating errors, warnings and diagnostics . Data type 2.	0.1 bps
3. Status/Housekeeping	Housekeeping, Time Correlation, and Status. Data type 4.	0.8 bps
4. OSS Near-Real-Time Acceleration Measurements	OSS Acceleration Measurements at 10 samples per second plus ancillary data, either filtered or unfiltered. Data type 3.	543 bps
5. OSS Stored Acceleration Measurements	OSS Acceleration Measurements and ancillary data--stored Near-Real-Time data, either filtered or unfiltered. Data type 5.	543 bps, For dump, rate can be controlled from 1 to 200 kbps
6. HiRAP Raw Acceleration Measurements	HiRAP Acceleration Measurements. Data type 1.	50 kbps
7. MAMS Parameter List Series of text messages	Current Operational Adaptation Parameters. Data type 2.	not applicable

- *Message Types 2-7 transmission can be modified via commands (and adaptation parameters)*
- * *Express Secondary Header Telemetry Data Type per IDD Table 11-VI*



MAMS FLIGHT CONFIGURATION



6 March 2001

Canopus Systems Inc.

MEIT-2001 / Section 5 / Page A.10

MAMS DESIGN/DEVELOPMENT TEAM