



---

## ***Section 20***

# ***ISS Design Analysis Cycle & Environment Predictions***

**Brad Humphreys**

**ZIN Technologies**

**216-977-0360**

**March 6<sup>th</sup>, 2003**

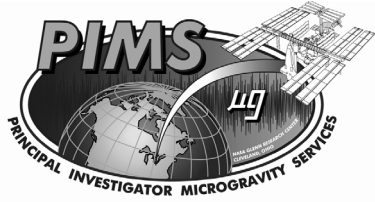

## Acknowledgements

---



- **Boeing JSC – Microgravity Team**
  - **Material previously presented by:**
    - Steve Del Basso (Boeing) DAC9/NIRA Requirements
    - Michael Laible (Boeing), Quasi Steady
    - Sree Thampi (Boeing), Vibratory
    - Ed O'Keefe (Boeing), VibroAcoustic

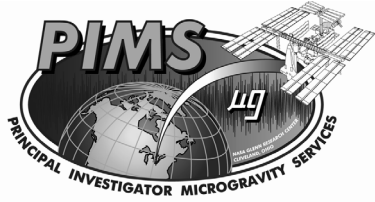

## Presentation Overview

---

- **Analysis Cycles**
  - **Design Analysis Cycles, DAC**
  - **Verification Analysis Cycles, VAC**
  - **Non Isolated Rack Assessment, NIRA**
- **Allocations**
- **Quasi – Steady Environment**
  - **Methods & Tools**
  - **Disturbers**
  - **Results**
- **Vibratory Environment**
  - **Methods & Tools**
  - **Disturbers**
  - **Results**
- **Summary**

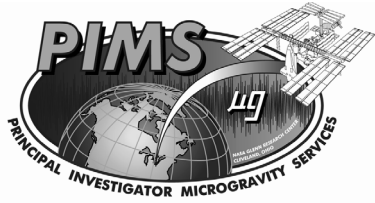

## Acronyms

---

- AC : Assembly Complete**
- ARIS : Active Rack Isolation System**
- COF : Columbus Orbital Facility**
- DAC : Design Analysis Cycle**
- EF : Exposed Facility**
- ELM : Experiment Logistics Module**
- GN&C: Guidance, Navigation, and Control**
- ISPR : International Standard Payload Rack**
- JEM : Japanese Experiment Module**
- NIRA : Non Isolated Rack Assessment**
- PIDS : Prime Item Development Specification**
- PM : Payload Module**
- RS : Russian Segment**
- SSP : Space Station Program**
- USOS: United States On-orbit Segment**
- VAC : Verification Analysis Cycle**

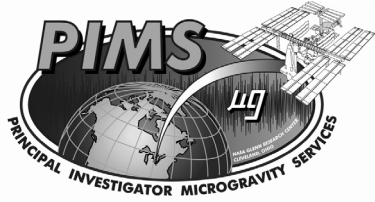

## Design Analysis Cycles

---

**DACs may be viewed as PDR/CDR level analyses or “special” case studies.**

- DAC-9 was completed in March 2002.
- DACs capture updated models & disturbance forcing functions.
- System model developed for Assembly-Complete (AC) configuration when micro-g requirements become applicable.
- System model development is an evolutionary process through Design Analysis Cycles (DAC). Current cycle is DAC-9.
- Each cycle reflects the current assembly sequence and the updated component models. Test-verified (VAC quality) models are available for components that have already flown.



## Verification Analysis Cycles

---

**Verification Analysis Cycles (VACs) are in process and are conducted on a increment by increment basis.**

- Verify that the hardware launched complies with Assembly Complete microgravity requirements.
- Priority tasks necessary for Certification of Flight Readiness.
- Example: ISS Stage 6A Quasi-Steady environment (as measured by MAMS) and SSMRBS was correlated (using actual Solar Flux Data, actual array configuration, and vehicle attitude). Model to environment deviation was only 3-4%.

### **Microgravity sustaining engineering efforts underway**

- Use of on-orbit measurements for issue resolution, uncertainty reduction, analytical model correlation.
- Support anomaly resolution and operations.

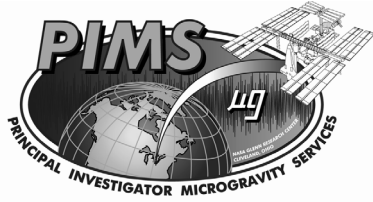

## Non Isolated Rack Analysis



### Non – Isolated Rack Assessment (NIRA)

- Uses the DAC model
- Latest Version completed 1999
- Next update June 2003
- Reports  $\mu\text{g}$  at rack interfaces on a per element (US LAB, JEM, etc.) basis
- Assumptions/Limitations
  - Station in  $\mu\text{g}$  mode
  - Includes payload and crew disturbances
  - Does not include active (ARIS) or passive isolation at the crew interface
- Data used by payload developers
  - More conservative since all payload disturbances are included
  - Developer simulates lab to rack isolation technique based on their specific rack configuration

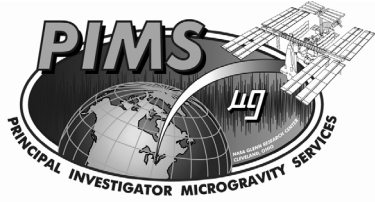

## DAC/NIRA Comparison

---

---

### DAC

- **Vehicle Disturbers /Response**
- **Does not include Payload Disturbers**
- **Includes Crew exercise devices**
- **Includes Active Rack Isolation System (ARIS)**
- **Used to show vehicle compliance to  $\mu\text{g}$  specification requirements**

### NIRA

- **Payload Disturbers (Based on Allocations)**
- **Does not include rack isolation**
- **Used to predict  $\mu\text{g}$  requirements at rack interfaces**
- **All other disturbance sources provided through DAC analyses**





## Allocations

### Combined Vibratory Acceleration Requirements

Sub-allocation of System Allowable

19.5 % to COF Segment.

19.5 % to JEM Segment.

19.5 % to Russian Segment.

Rest to USOS Segment:

Node 3, CRV, Hab, US Lab,  
CAM, Cupola, X-PM

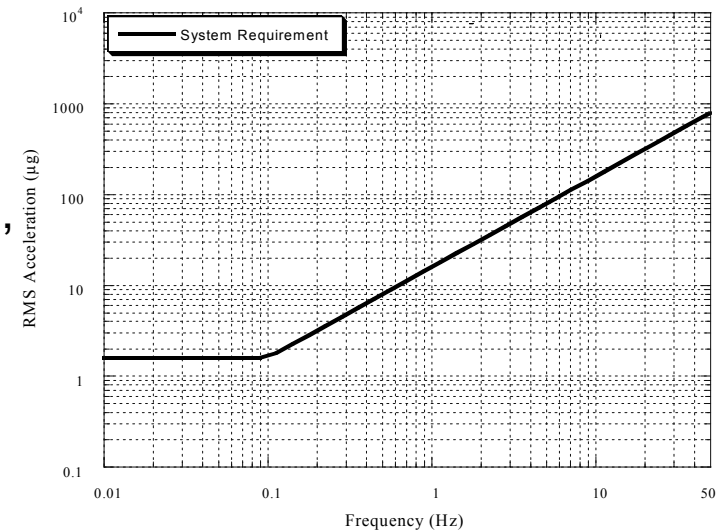

### Individual Transient Acceleration Requirements

- Instantaneous magnitude limit of 1000 µg per axis.
- Integrated acceleration limit of 10 µg-sec per axis over any 10-sec interval.

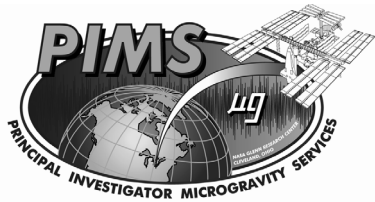

# Allocations Rack Locations



## ISPR Locations in Station Analysis Coordinate Frame (ft) Shaded areas not applicable to μg requirement

ISPR RACK LOCATIONS				OTHER POINT OF INTEREST			
X	Y	Z	Description	X	Y	Z	Description
15.62	0.00	11.16	USL-O1	35.14	0.00	-4.88	CAM MID
12.12	0.00	11.16	USL-O2	35.14	0.00	-11.44	CAM TOP
8.62	0.00	11.16	USL-O3	-17.66	-1.32	14.80	SYSTEM-C
5.12	0.00	11.16	USL-O4	36.08	19.87	11.16	APM-CLG3
1.62	0.00	11.16	USL-O5	36.08	23.42	11.16	APM-CLG4
15.62	4.75	15.91	USL-S1	48.41	-47.16	22.70	JEF1-F1
12.12	4.75	15.91	USL-S2	28.44	-47.16	22.70	JEF2-A1
8.62	4.75	15.91	USL-S3	47.82	-50.77	22.70	JEF3-F2
5.12	4.75	15.91	USL-S4	29.03	-50.77	22.70	JEF4-A2
15.62	-4.75	15.91	USL-P1	47.82	-54.38	22.70	JEF5-F3
12.12	-4.75	15.91	USL-P2	29.03	-54.38	22.70	JEF6-A3
5.12	-4.75	15.91	USL-P4	48.41	-57.99	22.70	JEF7-F4
30.39	-12.31	15.91	JPM1-A1	28.44	-57.99	22.70	JEF8-A4
39.89	-12.31	15.91	JPM2-F1	41.87	-64.44	22.70	JEF9-O1
30.39	-15.81	15.91	JPM3-A2	34.98	-64.44	22.70	JEF10-O2
39.89	-15.81	15.91	JPM4-F2	41.44	-54.38	14.81	JEF11-U1
30.39	-19.31	15.91	JPM5-A3	37.81	-58.45	14.81	JEF12-U2
39.89	-19.31	15.91	JPM6-F3	-3.35	79.54	7.12	S3LO
30.39	-22.81	15.91	JPM7-A4	-3.35	71.00	7.12	S3LI
30.39	-26.31	15.91	JPM8-A5	-3.35	79.54	-7.12	S3UO
39.89	-26.31	15.91	JPM9-F5	-3.35	71.00	-7.12	S3UI
39.89	-29.81	15.91	JPM10-F6	-3.35	-79.54	7.12	P3LO
35.14	12.68	11.16	APM-CLG1	-3.35	-79.54	-7.12	P3UO
35.14	16.22	11.16	APM-CLG2	-54.98	-0.03	13.71	FGB-CG
39.89	12.68	15.91	APM-FWD1	-97.85	-0.03	13.23	SM-CG
39.89	16.22	15.91	APM-FWD2	6.79	-0.16	16.14	USL-CG
39.89	19.87	15.91	APM-FWD3	35.31	-24.92	15.56	JEM-CG
39.89	23.42	15.91	APM-FWD4	35.14	17.83	15.91	APM-CG
30.39	12.68	15.91	APM-AFT1				
30.39	16.22	15.91	APM-AFT2				
30.39	19.87	15.91	APM-AFT3				
30.39	23.42	15.91	APM-AFT4				



## Quasi-Steady Analysis Methods & Tools



- **Perform integrated analysis to ensure microgravity quasi-steady disturbances will not exceed microgravity quasi-steady acceleration limits for the Assembly Complete International Space Station using the  $\mu\text{g}$  control plan inputs.**
- **System Level**
  - **Frequencies < .01 Hz, 1.0  $\mu\text{g}$  Peak and .2  $\mu\text{g}$  perpendicular component**
- **Element level**
  - **Quasi-steady microgravity requirements flow down to the PIDS as an allocation of .02  $\mu\text{g}$  on individual disturbances, excluding the effect of drag and gravity gradient. US LAB and HAB are allocated 0.04  $\mu\text{g}$  each for all combined quasi-steady disturbances**
- **Quasi-Steady Individual Disturbance defined as:**
  - **Quasi-steady disturbance is defined as having 95% of its power below .01 Hz in any 5400 second period**
    - Any step function greater than 200 seconds
    - Any exponential decay with a time constant greater than 200 seconds
    - Other disturbances analyzed for percentage content below .01 Hz
- **Perform studies to compare Orbiter attached, Core complete mass properties, Max and no aero runs**

# Quasi-Steady Analysis Methods & Tools

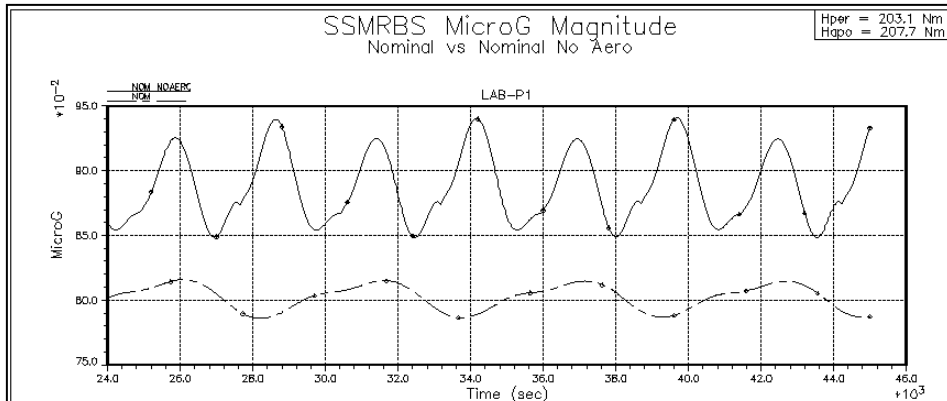

- Below 0.01 Hz**
- **Orbital Mechanic Multi-Rigid Body Closed Loop Attitude Control Analysis**
  - **Space Station Multi Rigid Body Simulation (NASA SPARC)**
  - **SSMRBS used for GN&C Software Verification**

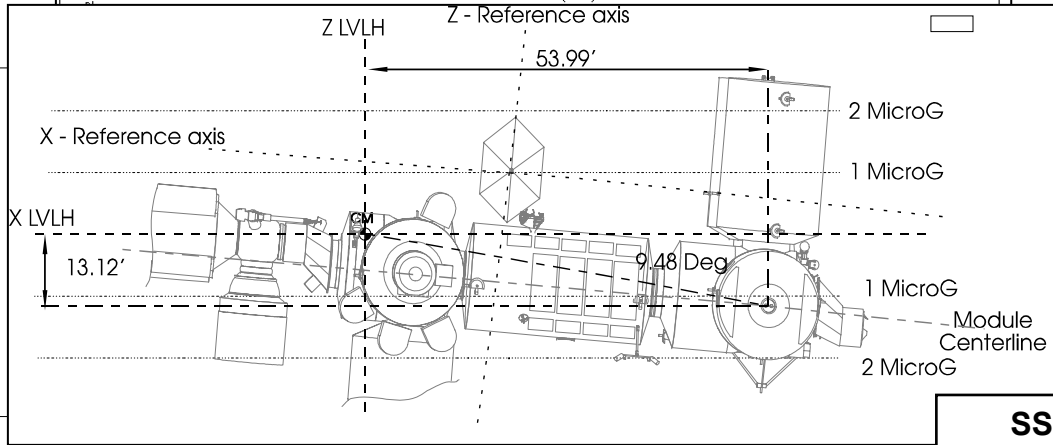

$$\vec{a} = -\mu \left( \frac{\vec{r}_p}{r_p^3} - \frac{\vec{r}_g}{r_g^3} \right) - \vec{\omega} \times \left( \vec{\omega} \times \vec{r}_{p/g} \right) - \dot{\vec{\omega}} \times \vec{r}_{p/g} + \vec{a}_D$$

Gravity Gradient      Centripetal      Tangential      Aerodynamic Drag

**SSMRBS Environment Data Validation**

**verify\_gfield (gravity)**

ADA Advanced Simulation Development System (ASDS)  
Gravitational Potential (GOTPOT) model

**verify\_bfield (magnetic)**

Goddard Space Flight Center International Geophysical Reference Field (IGRF) Earth Magnetic model

**verify\_atm\_density (density)**

Marshall Engineering Thermosphere (MET) Earth Atmospheric Density model

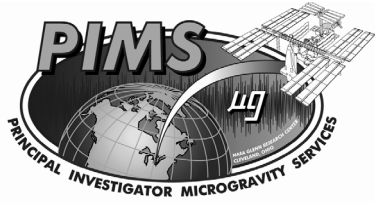

## Quasi-Steady Analysis Disturbance Inputs

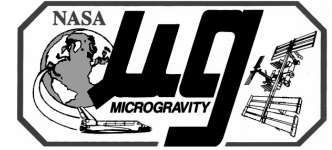

- **Centrifuge startup and shut down**
  - Spin-up for 120 sec to 236 deg/s, spin for 6.4 hours, spin-down for 120 sec.
  - Starts at 17000 sec
- **TRRJ slew at low betas**
  - TRRJ 0 beta slew rates - TRRJ Torque Power Spectral Density has 87.7% of its power below .01 Hz.
  - Not Applicable
- **Solar Thermal base loads**
  - Exponential decay for 210 seconds every 2160 seconds (night), 3360 (day), forces combined for eight arrays
  - Lighting dependent , continuous
- **LAB4 Vent**
  - Force profile, duration of 8700 seconds
  - Starts at 6000 seconds
- **RSA6 Vent**
  - Exponential decay of 600 seconds every 9000 seconds
  - Starts at 10000 seconds
- **Treadmill Gyro Start-up**
  - +.23 ft-lbs. for 10minutes, 0 ft-lbs. for 60 minutes, -.23 ft-lbs. for 10 minutes, repeated every 30 minutes.
  - Starts at 6000 seconds

# Quasi-Steady Results DAC 9 – Assembly Complete

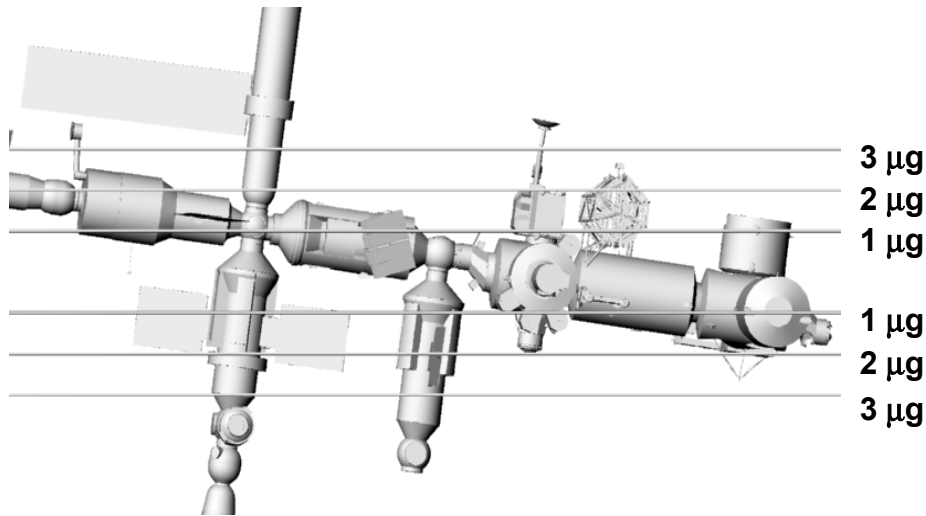

Some elements not shown

**Quasi-steady Performance:**

- 14 of 32 ISPRs < 1.0  $\mu\text{g}$
- All satisfy stability criteria

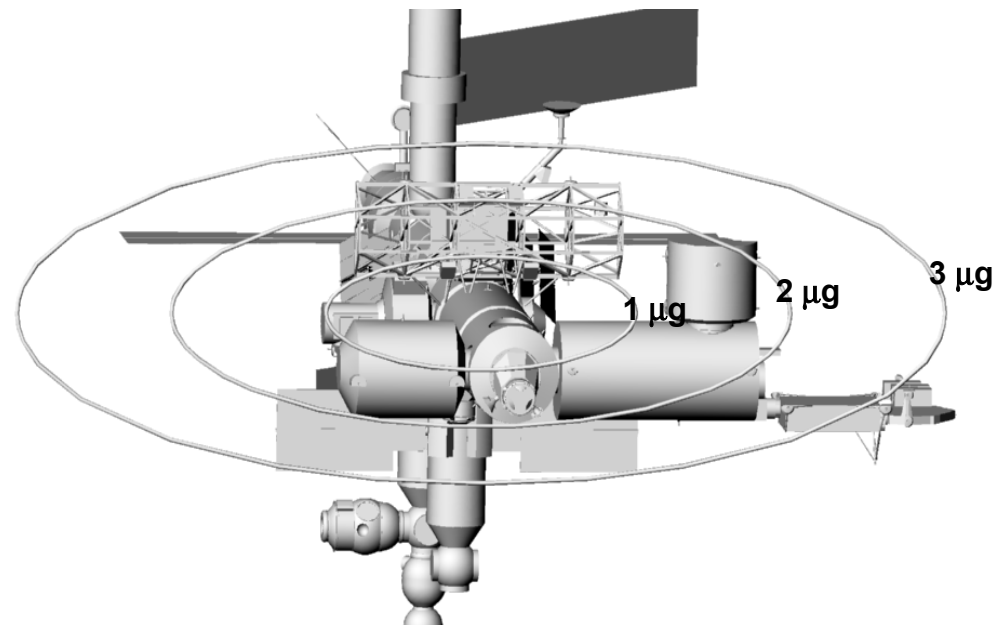

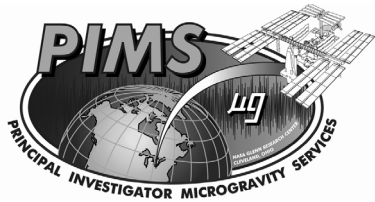

# Quasi-Steady Results DAC 9 – Assembly Complete



Location	μG Vector		Unit Vector			Cone Angle	Location	μG Vector		Unit Vector			Cone Angle
	Magnitude (μG)	⊥ Component (μG)	X	Y	Z	Max angle from unit vector (deg)		Magnitude (μG)	⊥ Component (μG)	X	Y	Z	Max angle from unit vector (deg)
CG	0.234	0.038	-0.995	-0.090	0.030	20.885	CAM-MID	1.518	0.111	0.068	-0.104	0.992	4.281
USL-C1	0.298	0.083	-0.630	-0.500	-0.594	18.659	CAM-TOP	2.306	0.111	0.093	-0.060	0.994	2.794
USL-C2	0.266	0.066	-0.751	-0.529	-0.395	22.312	APM-CLG3	0.875	0.116	-0.318	0.711	-0.627	7.587
USL-C3	0.244	0.045	-0.854	-0.518	-0.054	22.811	APM-CLG4	0.990	0.117	-0.296	0.773	-0.561	6.815
USL-C4	0.237	0.059	-0.830	-0.411	0.378	23.246	JEF1-F1	2.980	0.121	-0.057	-0.749	-0.660	2.388
USL-C5	0.245	0.085	-0.672	-0.249	0.698	24.359	JEF2-A1	2.682	0.115	-0.049	-0.795	-0.605	2.511
USL-S1	0.796	0.107	-0.315	0.096	-0.944	7.781	JEF3-F2	3.074	0.122	-0.049	-0.772	-0.633	2.336
USL-S2	0.743	0.105	-0.330	0.128	-0.935	8.237	JEF4-A2	2.800	0.116	-0.041	-0.814	-0.579	2.431
USL-S3	0.691	0.104	-0.348	0.165	-0.923	8.739	JEF5-F3	3.181	0.123	-0.042	-0.793	-0.608	2.286
USL-S4	0.642	0.102	-0.369	0.208	-0.906	9.291	JEF6-A3	2.914	0.117	-0.034	-0.833	-0.552	2.364
USL-P1	0.811	0.107	-0.247	-0.401	-0.882	7.632	JEF7-F4	3.299	0.125	-0.036	-0.809	-0.586	2.238
USL-P2	0.754	0.105	-0.259	-0.412	-0.874	8.124	JEF8-A4	3.022	0.119	-0.026	-0.850	-0.526	2.306
USL-P4	0.641	0.102	-0.288	-0.439	-0.851	9.320	JEF9-O1	3.412	0.127	-0.022	-0.849	-0.528	2.181
JPM1-A1	1.187	0.111	-0.159	-0.593	-0.789	5.480	JEF10-O2	3.321	0.124	-0.018	-0.862	-0.506	2.198
JPM2-F1	1.349	0.114	-0.154	-0.556	-0.817	4.959	JEF11-U1	2.599	0.123	0.005	-0.944	-0.330	2.766
JPM3-A2	1.266	0.111	-0.135	-0.669	-0.731	5.143	JEF12-U2	2.714	0.124	0.015	-0.957	-0.289	2.663
JPM4-F2	1.422	0.114	-0.134	-0.628	-0.766	4.705	S3LO	3.268	0.163	-0.125	0.982	0.141	2.877
JPM5-A3	1.355	0.111	-0.114	-0.730	-0.674	4.809	S3LI	2.931	0.155	-0.125	0.978	0.165	3.072
JPM6-F3	1.506	0.114	-0.115	-0.688	-0.716	4.449	S3UO	3.950	0.152	-0.042	0.830	0.556	2.272
JPM7-A4	1.453	0.111	-0.094	-0.779	-0.620	4.491	S3UI	3.683	0.145	-0.034	0.797	0.603	2.324
JPM8-A5	1.558	0.112	-0.077	-0.817	-0.571	4.197	P3LO	3.374	0.122	0.104	-0.958	0.269	2.078
JPM9-F5	1.696	0.114	-0.081	-0.779	-0.622	3.963	P3UO	4.202	0.113	0.142	-0.764	0.629	1.546
JPM10-F6	1.801	0.115	-0.067	-0.812	-0.579	3.745	FGB-CG	1.487	0.121	-0.028	0.851	0.525	4.741
APM-CLG1	0.668	0.112	-0.369	0.498	-0.785	9.613	SM-CG	1.651	0.106	0.030	0.265	0.964	3.990
APM-CLG2	0.759	0.113	-0.344	0.631	-0.695	8.593	USL-CG	0.664	0.103	-0.326	-0.138	-0.935	9.030
APM-FWD1	1.246	0.116	-0.263	0.227	-0.938	5.338	JEM-CG	1.560	0.113	-0.083	-0.795	-0.601	4.246
APM-FWD2	1.300	0.116	-0.265	0.330	-0.906	5.144	APM-CG	1.267	0.116	-0.272	0.410	-0.871	5.247
APM-FWD3	1.369	0.117	-0.265	0.422	-0.867	4.919							
APM-FWD4	1.449	0.118	-0.262	0.500	-0.826	4.693							
APM-AFT1	1.110	0.113	-0.281	0.299	-0.912	5.869							
APM-AFT2	1.174	0.114	-0.280	0.407	-0.869	5.595							
APM-AFT3	1.254	0.115	-0.276	0.501	-0.820	5.295							
APM-AFT4	1.342	0.117	-0.270	0.576	-0.772	5.005							

- Rack count 14 of 32 less than 1 μg
- Good stability, all 32 racks below .2 μg

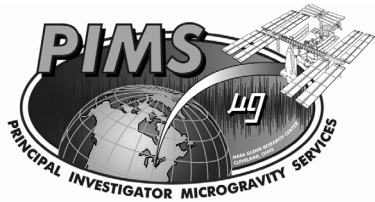

## Quasi-Steady Results DAC 9 - Assembly Complete, Comparison



**14 of 32 racks less than 1  $\mu$ g magnitude**

Configuration	CG			Principle Axis			Mass	Rack count under 1 $\mu$ g
	X-ft	Y-ft	Z-ft	Y-deg	P-deg	R-deg	lb.	
7/15/94	-24.77	-0.7	13.55	-5.1	-3.31	0.12	836955	18
3/13/95 (DAC1)	-23.49	-2.26	12.67	-8.15	-4.13	-0.23	896110	16
DAC2	-23.41	-3.02	11.71	-6.17	-4.15	0.08	855301	14
DAC3	-23.07	-1.51	12.9	-1.24	-5.53	0.49	893181	11
DAC4	-21.23	-0.96	15.51	-3.34	-8.28	0.27	893045	14
DAC5	-22.08	-1.19	15.82	-4.05	-9.41	0.1	900412	10
DAC6	-19	-1.18	14.7	-3.26	-7.25	0.37	920170	14
DAC7	-16.21	-0.67	14.74	-5.87	-8.15	-0.16	994969	14
DAC8	-15.34	-1.28	14.87	-8.44	-6.13	0.12	1035473	15
DAC9	-17.66	-1.32	14.8	-6.36	-7.04	0.28	1005479	14
DAC9_CORE	-19.35	-0.59	14.93	-12.55	-10.53	-0.59	947788	10
DAC9_CORE_ADJ	-16.27	-0.63	13.76	-8.78	-9.93	0.14	902738	8
DAC9_ORB	-4.24	-1.09	22.03	8.97	9.49	-1.1	1222209	2
DAC9_CORE_ORB	-4.94	-0.49	22.5	15.4	5.96	-0.76	1164518	3
DAC9_CORE_ORB_ADJ	-1.88	-0.51	21.86	32.12	7.19	-3.68	1119471	4



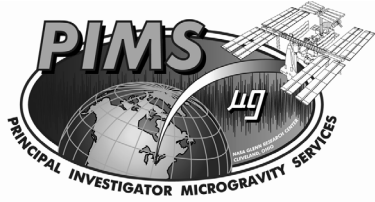

## Quasi-Steady Results DAC 9 - Core Complete



- **US Core Complete**
  - US less Node 3, CRV, and HAB
  - RSA includes reduced SPP, 2-Soyuz, Multi-Purpose Module (MPM), RM1, RM2, No DC2
- Using preliminary mass properties developed by Microgravity group
- Quasi-steady numbers are **PRELIMINARY**
- Mass Properties were developed by:
  - Subtracting all RSA elements from core body
  - Subtracting N3 and Hab from core body
  - Adding back new RSA mass properties to core body (delivered from assy. and manifest group, Nancy Wilks)
  - Reduced flat plate area accordingly (1/2 SPP, removed appropriate areas for N3,CRV,HAB)



# Quasi-Steady Results DAC 9 - Core Complete



Location	μG Vector		Unit Vector			Cone Angle	Location	μG Vector		Unit Vector			Cone Angle
	Magnitude (μG)	⊥ Component (μG)	X	Y	Z	Max angle from unit vector (deg)		Magnitude (μG)	⊥ Component (μG)	X	Y	Z	Max angle from unit vector (deg)
CG	0.228	0.039	-0.983	-0.161	0.087	21.717	CAM-MID	1.155	0.110	0.146	-0.335	0.931	5.503
USL-C1	0.535	0.104	-0.309	-0.561	-0.768	11.220	CAM-TOP	1.909	0.109	0.170	-0.187	0.967	3.321
USL-C2	0.460	0.101	-0.343	-0.602	-0.721	12.719	APM-CLG3	1.094	0.115	-0.361	0.314	-0.878	6.022
USL-C3	0.390	0.096	-0.391	-0.659	-0.643	14.425	APM-CLG4	1.167	0.116	-0.364	0.416	-0.833	5.690
USL-C4	0.328	0.090	-0.458	-0.734	-0.502	15.983	JEF1-F1	3.430	0.119	-0.041	-0.723	-0.690	2.039
USL-C5	0.279	0.079	-0.539	-0.810	-0.230	19.577	JEF2-A1	2.981	0.112	-0.025	-0.774	-0.632	2.211
USL-S1	1.039	0.108	-0.302	-0.105	-0.948	6.011	JEF3-F2	3.510	0.120	-0.031	-0.745	-0.666	2.003
USL-S2	0.957	0.107	-0.317	-0.083	-0.945	6.459	JEF4-A2	3.096	0.113	-0.015	-0.793	-0.609	2.146
USL-S3	0.877	0.106	-0.335	-0.057	-0.941	6.975	JEF5-F3	3.608	0.121	-0.021	-0.765	-0.644	1.967
USL-S4	0.799	0.104	-0.356	-0.024	-0.934	7.575	JEF6-A3	3.201	0.114	-0.005	-0.812	-0.584	2.092
USL-P1	1.085	0.107	-0.212	-0.452	-0.866	5.720	JEF7-F4	3.721	0.122	-0.013	-0.781	-0.624	1.929
USL-P2	1.000	0.106	-0.219	-0.463	-0.859	6.147	JEF8-A4	3.297	0.115	0.005	-0.829	-0.559	2.044
USL-P4	0.833	0.104	-0.237	-0.491	-0.838	7.233	JEF9-O1	3.770	0.122	0.007	-0.823	-0.567	1.904
JPM1-A1	1.578	0.111	-0.136	-0.582	-0.802	4.105	JEF10-O2	3.628	0.120	0.014	-0.839	-0.544	1.935
JPM2-F1	1.814	0.113	-0.136	-0.551	-0.824	3.658	JEF11-U1	2.937	0.120	0.045	-0.908	-0.417	2.384
JPM3-A2	1.648	0.110	-0.112	-0.642	-0.759	3.925	JEF12-U2	3.015	0.120	0.059	-0.926	-0.372	2.323
JPM4-F2	1.879	0.113	-0.115	-0.606	-0.787	3.529	S3LO	3.111	0.151	-0.212	0.974	0.080	2.812
JPM5-A3	1.727	0.110	-0.089	-0.693	-0.716	3.742	S3LI	2.771	0.146	-0.212	0.972	0.102	3.032
JPM6-F3	1.953	0.113	-0.095	-0.654	-0.750	3.396	S3UO	3.683	0.143	-0.088	0.845	0.528	2.289
JPM7-A4	1.814	0.110	-0.068	-0.736	-0.673	3.563	S3UI	3.419	0.137	-0.074	0.812	0.579	2.366
JPM8-A5	1.907	0.110	-0.049	-0.773	-0.633	3.391	P3LO	3.420	0.115	0.198	-0.948	0.249	1.926
JPM9-F5	2.120	0.113	-0.059	-0.733	-0.677	3.134	P3UO	4.224	0.108	0.242	-0.759	0.604	1.464
JPM10-F6	2.213	0.113	-0.044	-0.765	-0.642	3.011	FGB-CG	1.876	0.116	0.012	0.843	0.538	3.610
APM-CLG1	0.973	0.113	-0.340	0.064	-0.938	6.678	SM-CG	2.218	0.105	0.080	0.305	0.949	2.863
APM-CLG2	1.015	0.114	-0.356	0.202	-0.912	6.433	USL-CG	0.860	0.105	-0.291	-0.275	-0.916	7.063
APM-FWD1	1.647	0.116	-0.277	0.002	-0.961	4.057	JEM-CG	1.951	0.112	-0.059	-0.748	-0.661	3.359
APM-FWD2	1.671	0.116	-0.291	0.086	-0.953	4.005	APM-CG	1.582	0.115	-0.306	0.157	-0.939	4.192
APM-FWD3	1.709	0.117	-0.302	0.169	-0.938	3.928							
APM-FWD4	1.761	0.118	-0.310	0.244	-0.919	3.836							
APM-AFT1	1.424	0.113	-0.299	0.059	-0.952	4.582							
APM-AFT2	1.461	0.114	-0.312	0.154	-0.938	4.487							
APM-AFT3	1.513	0.115	-0.322	0.245	-0.915	4.361							
APM-AFT4	1.575	0.116	-0.328	0.325	-0.887	4.222							

• 10 racks under 1 μg

# Quasi-Steady Results DAC 9 - Core Complete

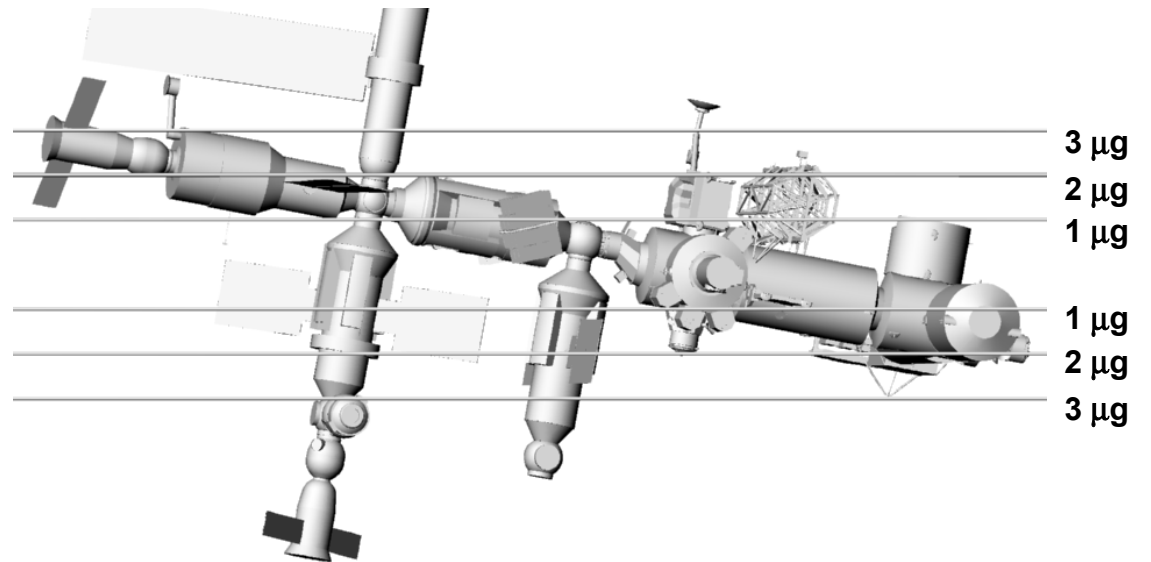
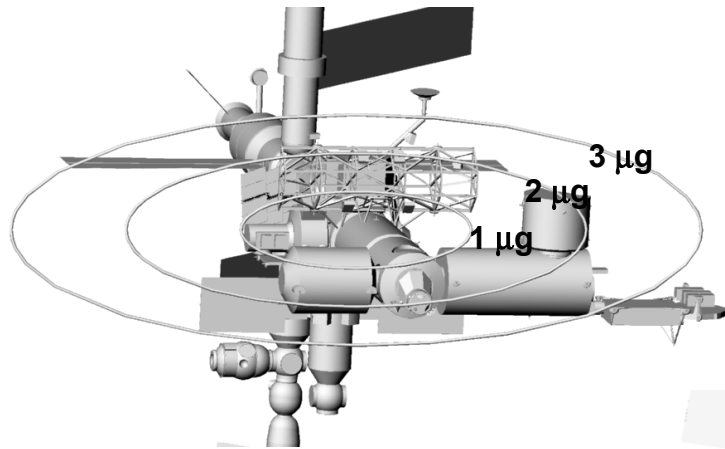

# Vibratory Analysis (Structural Dynamic) Methods & Tools

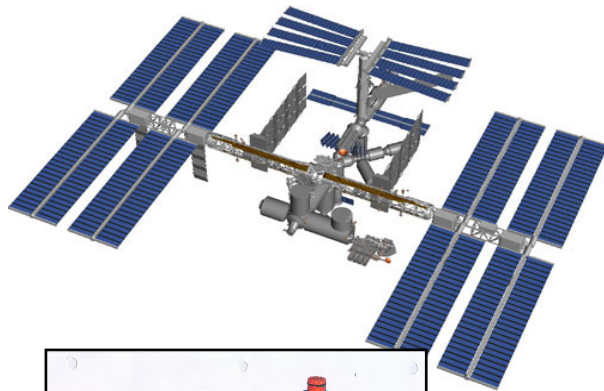

Enhanced COF Model

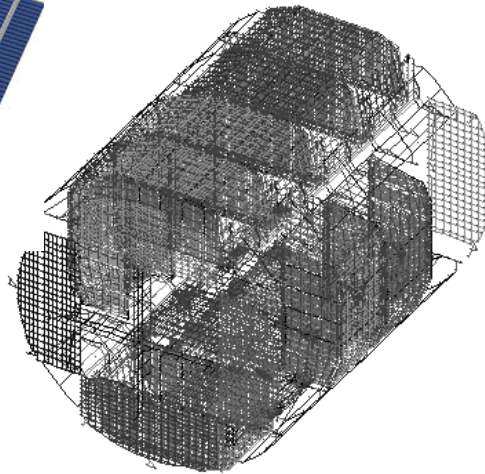

**0.01 to 50 Hz**  
Structural Dynamic Finite Element Analysis  
MSC/NASTRAN (NASA CRAY)  
"Enhanced" Loads & Dynamics Models

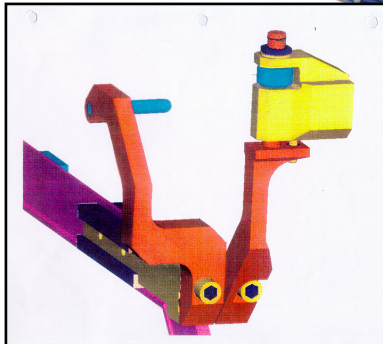
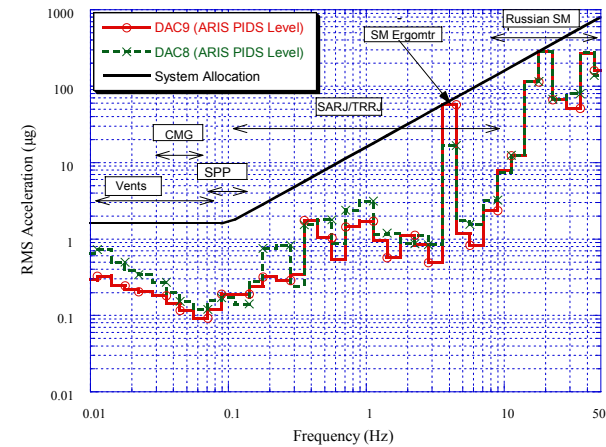

Lower Pivot

Non-isolated Rack I/F



Upper KBAR

Rack KBAR Attachment

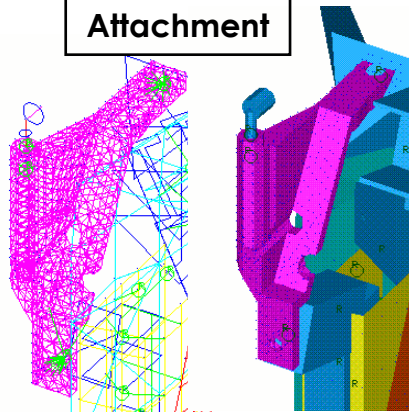

March 6, 2003

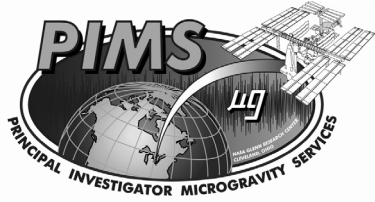

# Vibratory Analysis Methods and Assumptions

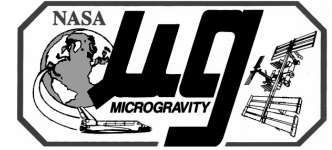

- “Structural dynamic” micro-gravity assessments (0 to 50 Hz.)
- Frequency domain analysis for steady-state disturbances
  - Analysis frequency vector superposition of 2 frequency sets
    - **8457 system modes resonant frequencies**
    - **2000 supplemental frequencies at constant logarithmic spacing.**
- Time domain simulations for transient disturbances
  - Simulations performed with 0.01 second time step to have Nyquist frequency of 50 hz
  - Simulations performed for 100 seconds provide data down to lower frequency limit of 0.01 hz.

## Damping

- 0.25% for all modes

## Attenuation

- ARIS attenuation applied
  - PIDS level
  - FCA verification level

# Vibratory Analysis Transfer Functions

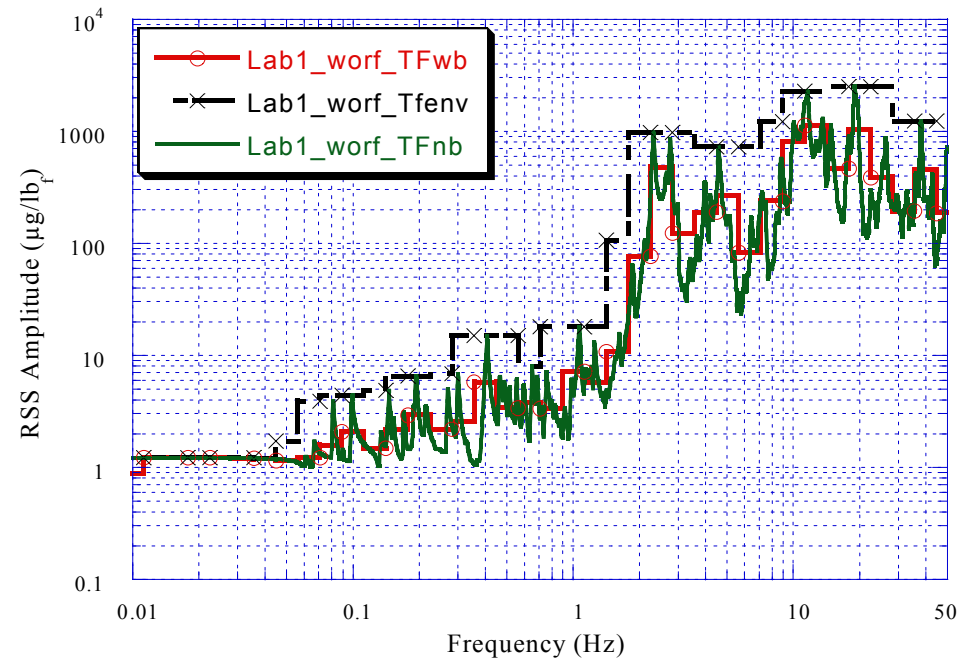
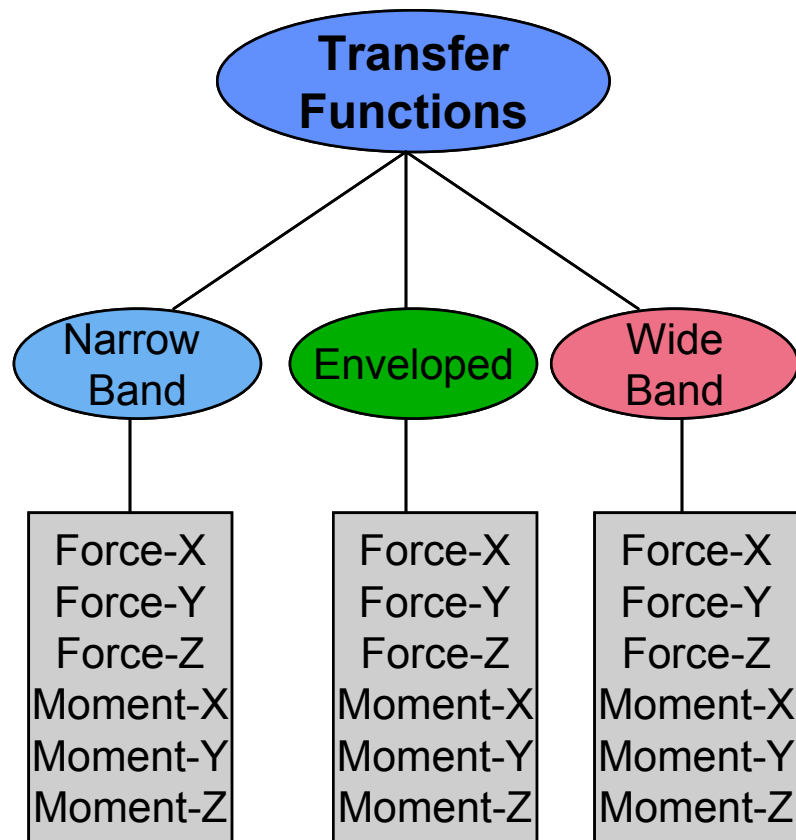

$$TF_{wb} = \sqrt{\frac{1}{\Delta F} \sum_{\Delta F} H(f)^2 \Delta f_{nb}}$$

where  $\Delta F$  is an 1/3 octave band

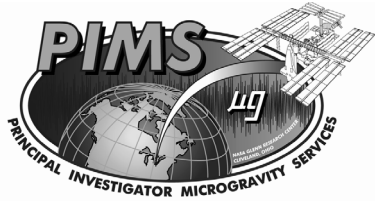

## Vibratory Analysis Finite Element Models



- Component models obtained from various sources - element developers, international partners.
- Models usually obtained through Loads & Dynamics AIT
- Some models obtained directly from source
- Models come in various formats: simple stick-beam representations, detailed bulk data, reduced mass/stiffness matrices.
- **CONFIGURATION**
  - DAC-8 system model represented Rev.C configuration. This was updated to Rev. F configuration for DAC-9, major differences in Russian segment.
  - Node 4 / Propulsion module not included.
- **COMPONENT MODELS**

	<b>SOURCE</b>
• US Laboratory Module (US Lab)	Boeing Hsv
• Japanese Experiment Module (JEM)	NASDA
• ESA Attached Pressurized Module (APM)	ESA
• Centrifuge Accommodation Module (CAM)	NASDA/ARC
• Node 2 and Node 3	Alenia
• Photo-Voltaic Arrays	Boeing CP

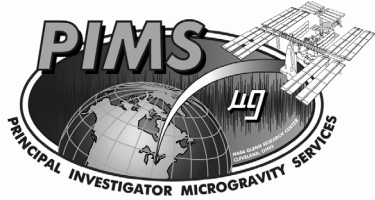

## Vibratory Analysis US Lab Finite Element Model

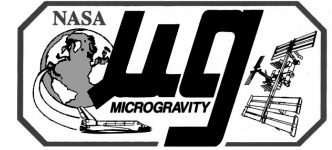

### US Lab Finite Element Model (Boeing, HSV)

- US Lab model comprised of 32 Super-elements: Shell, Forward ESS, Aft ESS, 4 Standoffs, LCA, 12 Racks, 12 Isolation Plates
- Includes detailed rack models and attachments - pivot pins, K-bars, knee braces, bayonet fittings. ARIS racks are not included.
- For DAC-9, **unique system rack models were used** rather than a generic rack model used for DAC-8.
- Craig-Bampton reduction performed on all US Lab component models. Modal content to 100 Hz. was retained. Total integrated weight 36325 lb.

### Experimental Validation

- Modal Survey Test performed by Boeing, Hsv., “Laboratory Module Dynamic Model Correlation Report,” Encl. to 2-8263-BKC-018-99
- Launch configuration - Common Module with one standoff, one rack, CBM’s, Mass Simulators for PMA.
- Frequency range for Model Correlation, 0 to 50 Hz.
- Deflection data from static testing and transfer function correlation studies to further validate on-orbit model.



# Vibratory Analysis DAC9 Finite Element Model

## Integrated US Lab Model

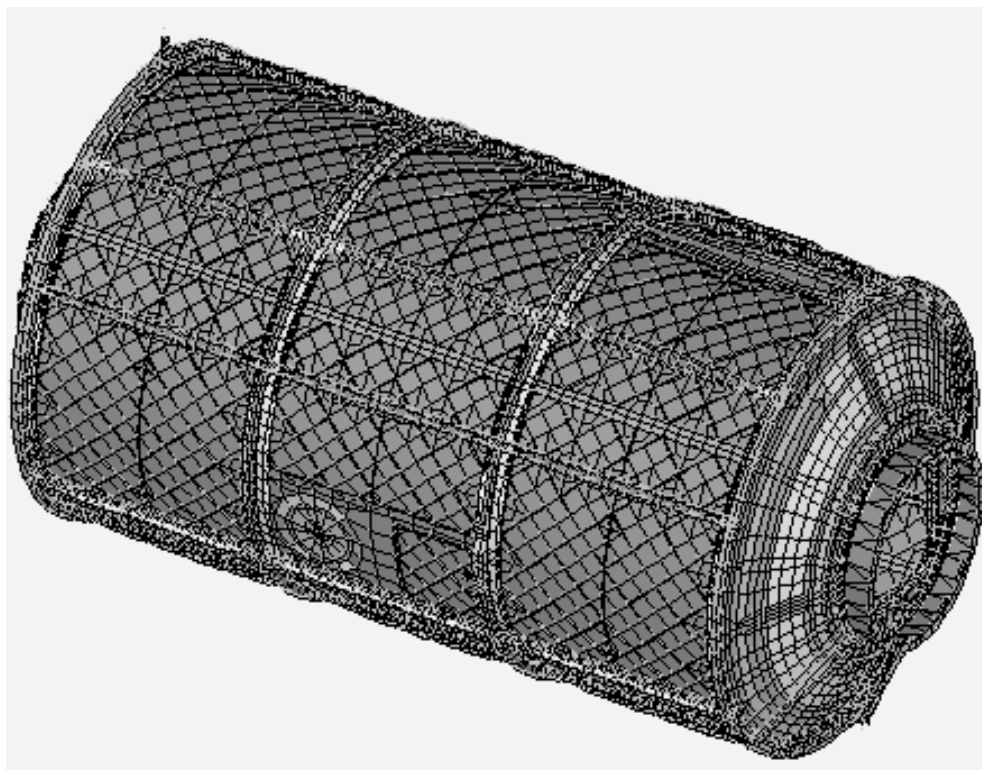

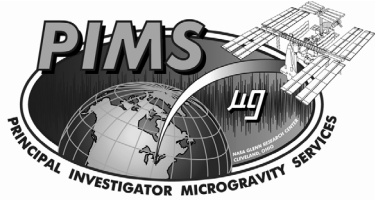

## Vibratory Analysis JEM Finite Element Model



### JEM Finite Element Model (NASDA)

- JEM model comprised of JEM-PM, ELM-PS, EF, and ELM-ES. Only the JEM-PM and ELM-PS were updated from DAC-8 to reflect latest design and structural test results (Rf. NU-98930, 2/3/2000).
- Includes detailed rack models (24 racks in PM, 8 racks in ELM-PS) and updated rack attachment hardware models (K-Bar, pivots).
- Craig-Bampton modal reduction performed on PM, ELM-PS and EF,
  - 942 modes to 100 Hz retained for JEM-PM and ELM-PS
  - 155 modes to 100 Hz retained for JEM-EF and ELM-ES
  - Total integrated weight is 103320 lb

### Experimental Validation

- Modal Survey test performed for PM, ELM-PS (launch configuration), and for EF, ELM-ES (launch and on-orbit configuration).
- Frequency range for Model Correlation, PM 25 Hz., EF 32 Hz., ELM-ES 17 Hz.
- Deflection data from static testing and local modal tests used to validate stiffness of equipment support structures and interfaces.

# Vibratory Analysis JEM Component Models

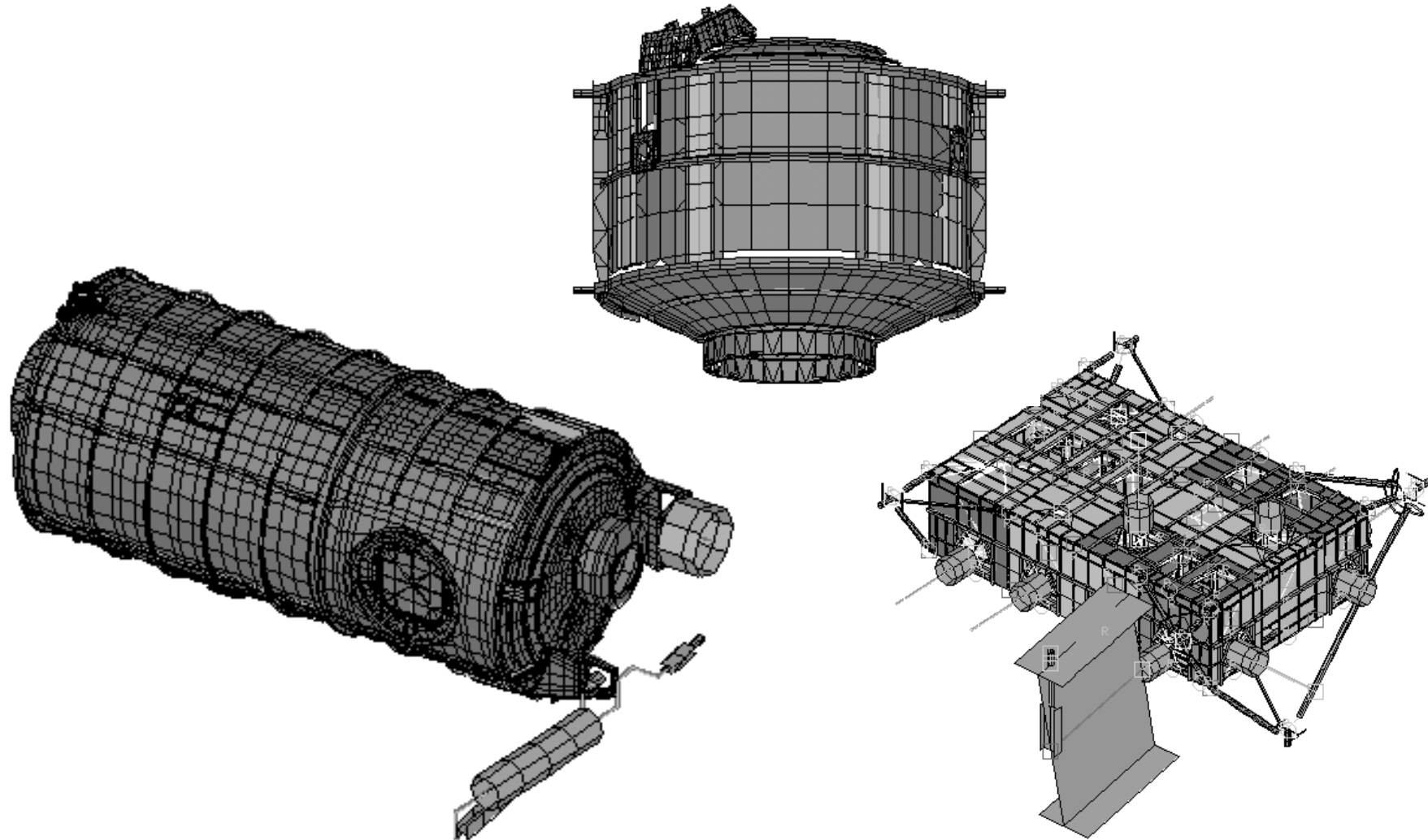

## COF Finite Element Model (ESA, Alenia)

- Detailed model of ESA-COF (COL-RP-AI-0202, 3/03/2000) comprising of
  - Primary structure: cylinder, cones, rings and fitting
  - 4 Stand-offs (Craig Bampton reduced format)
  - Hatch (Bulk data)
  - Common Berthing Mechanism (Bulk data)
  - Forward and Port internal structure (Bulk data)
  - External Platform (Bulk data)
  - Racks
    - 13 NASDA racks (CB reduced format)
    - 3 S/S racks (2 CB reduced format, 1 bulk data)
- Model reconfiguration
  - Remove racks F1,F2,A1,A2  
(Assumed location of ARIS racks): 1700 kg.
  - Change rack-to-module connections (OA/2) for racks A3, A4, F3, F4
- Model Reduction
  - Craig-Bampton modal reduction performed on ESA-COF, modal content: 1000 modes to 97 Hz.
  - Total integrated weight 42150 lb.

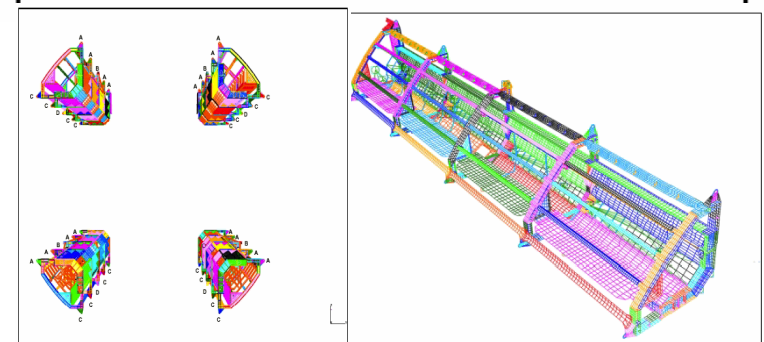
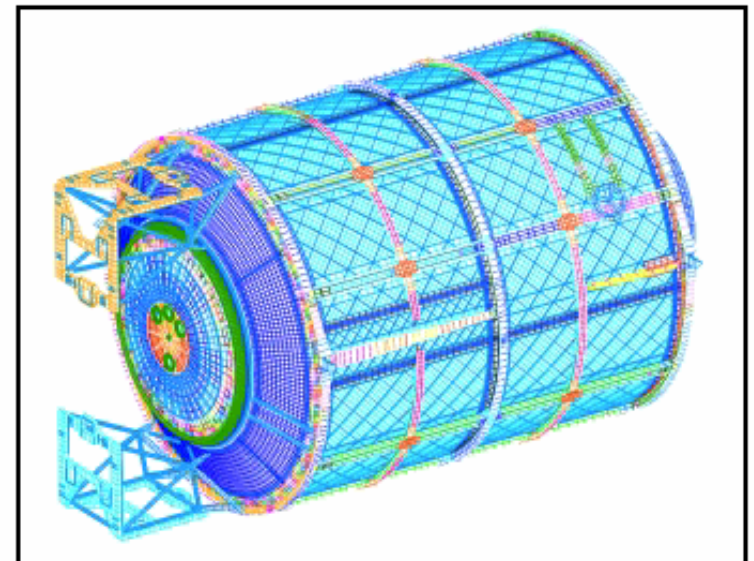

## Vibratory Analysis CAM Finite Element Model

### CAM Finite Element Model (NASDA, ARC)

- Detailed model of Centrifuge Accommodation Module including Centrifuge Rotor (Rf. NU-100293, 10/3/2000).
- CAM module generated based on the test-verified JEM-PM model.
- Includes detailed Centrifuge rack model and concentrated mass representation of other rack models.
- Craig-Bampton modal reduction performed on integrated CAM, modal content: 665 modes to 100 Hz .
- Centrifuge spin mode retained
- Total integrated weight 42620 lb.

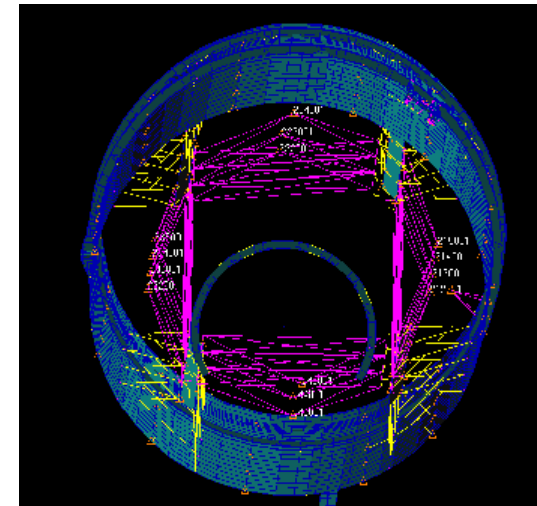

## Vibratory Analysis Node 2 Finite Element Model

### Node 2 Finite Element Model (Alenia, MSFC)

- Detailed model of Node 2 developed by Alenia (Rf. N2-RP-AI-0070, 2/1/2001, N2-RP-AI-0115, 2/23/2001).
- Model includes all primary and secondary structures
  - standoffs, mid-bay & alcove structure, fwd/aft cones, 4 DDCU racks, ISPR
- Identical model used for Node 2 and Node 3
- Model provided by Alenia as Craig-Bampton reduced mass and stiffness matrices.
  - modal content: 301 modes to 57 Hz
  - total weight 34900 lb.

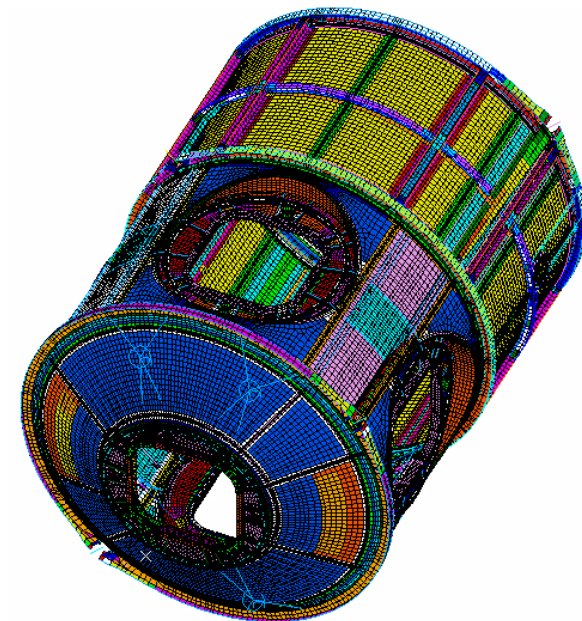

# Vibratory Analysis DAC9 FEM Transfer Functions

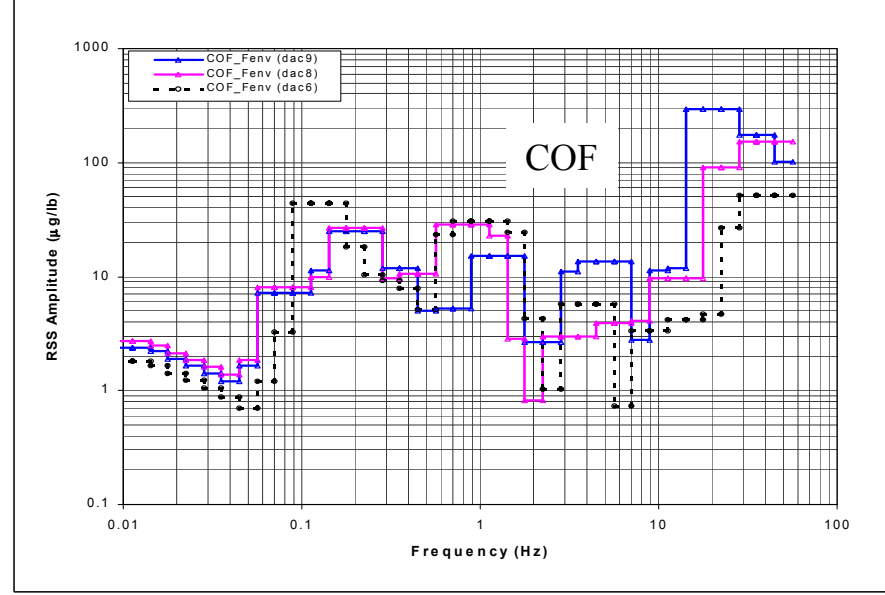
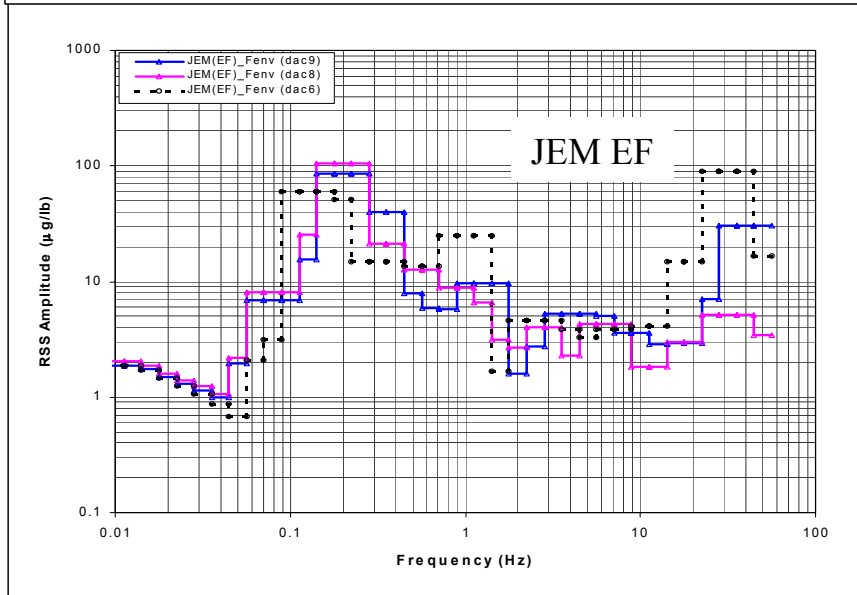
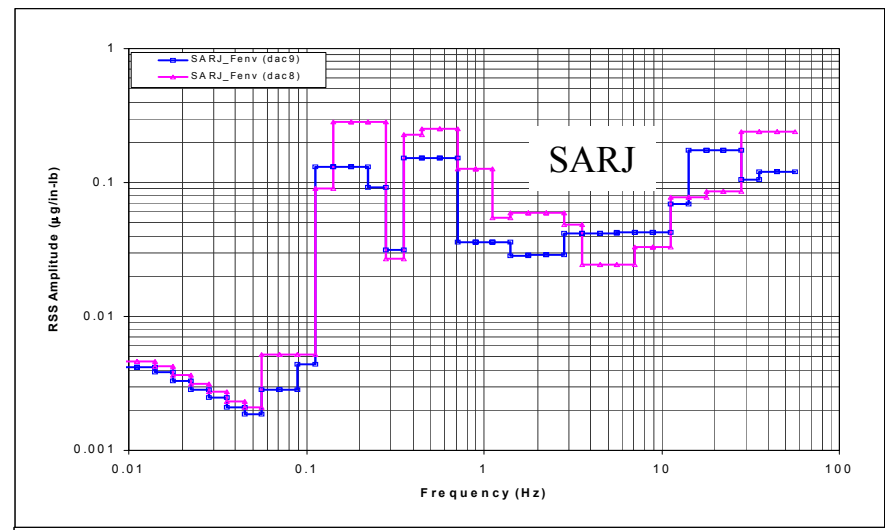
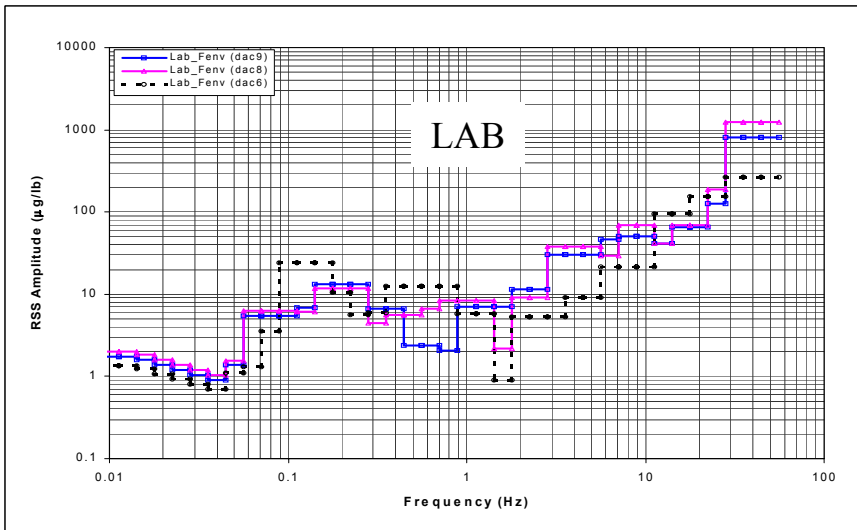

March 6, 2003

MEIT-2003 / Section 20 / Page 31

# Vibratory Analysis Disturbance Analysis & Testing

**NODE TEST**



**LAB TEST**

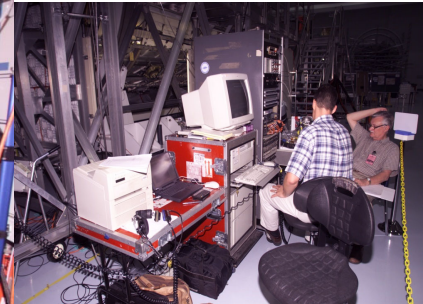
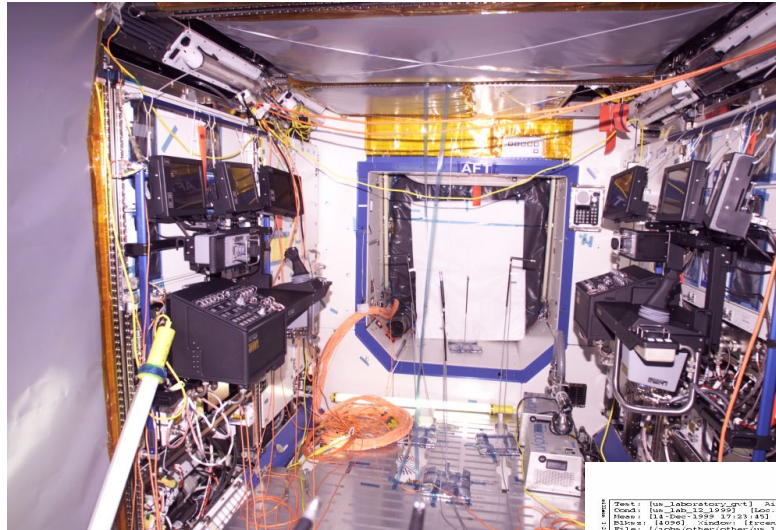

EQUIPMENT							
TYPE	ITEM	DACS VMDB	RS A OR U LOGISTICS	KHSC EN-10-01, P.2	PRIME DDB	COMMENTS	ASSESSED
SOLAR ARRAY	DRIVE	1	2	2	2		
FAN	TFC	2	11	8	8	VIB ONLY	X
	DUST COLLECTOR			2	2	VIB ONLY	X
	CONTROL SYSTEM			1	1	NQ	N/A
	CONTIN. FILTER			1	1	NQ	N/A
	TCS			2	2	1-VIB, 1-NQ	1-X, 1-N/A
	COMFORT	1	3	3	3	LOW POWER	N/A
	FIRE HAZARD			10	10	LOW POWER	N/A
	BANK OF FANS	1					
	LIFE SUPPORT	1	4				
PUMP	TCS	2		2	2	VIB ONLY	X
HEAT EXCH.	TCS - GAS/LIQUID	2		4	4	KHSC INS.G.	
VALVE	TCS RETURN	1		2	2	KHSC INS.G.	
	TCS REGULATOR	1		1	1	KHSC INS.G.	
	LIFE SUP. PRESS	1		1	1	KHSC INS.G.	
	LIFE SUP. PRESS REDUCTION	1		1	1	KHSC INS.G.	
	LIFE SUP. EQUAL	1		1	1	KHSC INS.G.	
	LIFE SUP. CNTRL	2		1	1	KHSC INS.G.	
TV	CAMERA	1		3 EXT-NQ	3 EXT-NQ	EXT & NQ	N/A
PHONE	LOUDSPEAKER	3	4	3	3	CONTINGENCY	N/A
TOTAL		22	24	45	45		

March 6, 2003

## Capture &

## Adequacy

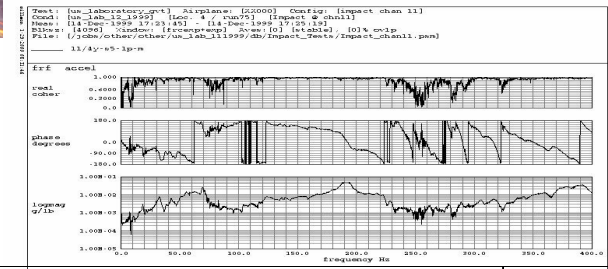

EQUIPMENT			PG/IP	DISTURBANCE COMPONENT ASSURACY (WEIGHTING * RATING)						ACCURACY RATING 0 <= AR <= 10	
TYPE	ITEM	NUMBER		QUASI-STEADY	VIBRATORY			ACOUSTICAL			
					NB	WB	TR	NB	WB	TR	
					Fndmtl.	Harmonics		Fndmtl.	Harmonics		
Flight 1A/R - FGB											
	ECLSS Fans	12	RS		8*8	4*8	2*0				6.4
	TCS Pumps	2	RS		8*6	4*6	2*0				4.8



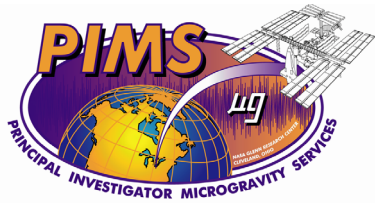

# Vibratory Analysis Forcing Functions - Database



Co. / Agency	BHV		
Item	Fan, AAA (175 W, nominal)		
Location (Number)	CS1 (17), CS2 CS3 (17), CS4 CS5 (17), CS6 CS7 (17), CS8		
Duty	0.2 for each fan		
References	144		
Bibliography	1, 2, 11, 17, 26, 38, 50, 52, 55, 56, 75		
Comments	vibrations force is assumed to be 0.115		
1/3-OB Ctr Freq, Hz	Time, s	Force, lb(rms)	Moment, in-lb(rms)
0.01		5.520E-04	
0.0125		6.175E-04	
0.016		6.960E-04	
0.02		7.810E-04	
0.025		8.730E-04	
0.0315		9.820E-04	
0.04		1.100E-03	
0.05		1.235E-03	
0.063		1.390E-03	
0.08		1.560E-03	
0.1		1.750E-03	
0.125		1.950E-03	
0.16		2.200E-03	
0.2		2.470E-03	
0.25		2.760E-03	
0.315		3.100E-03	
0.4		3.490E-03	
0.5		3.910E-03	
0.63		4.380E-03	
0.8		4.940E-03	
1		6.995E-04	
1.25		1.033E-03	
1.6		1.033E-03	
2		1.113E-03	
2.5		1.212E-03	
3.15		3.497E-03	
4		1.194E-03	
5		2.034E-03	
6.3		2.373E-03	
8		1.288E-03	
10		1.525E-03	
12.5		2.159E-03	
16		2.498E-03	
20		3.200E-03	
25		3.321E-03	
31.5		8.471E-03	
40		6.464E-03	
50		1.197E-02	4.450E+01
63		2.921E-02	4.450E+01
80		3.200E-02	4.450E+01
100		8.052E-02	4.120E+01
125		1.643E-01	4.120E+01
160		2.564E-01	4.120E+01
200		1.155E-01	5.200E+01
250		1.633E-01	5.200E+01
315		9.077E-02	5.200E+01

## DISTURBANCE DATABASE

**Pressurized Module Disturbances: Fans, Pumps, Valves, Coldplates, Ducts (Mechanical and Acoustic)**

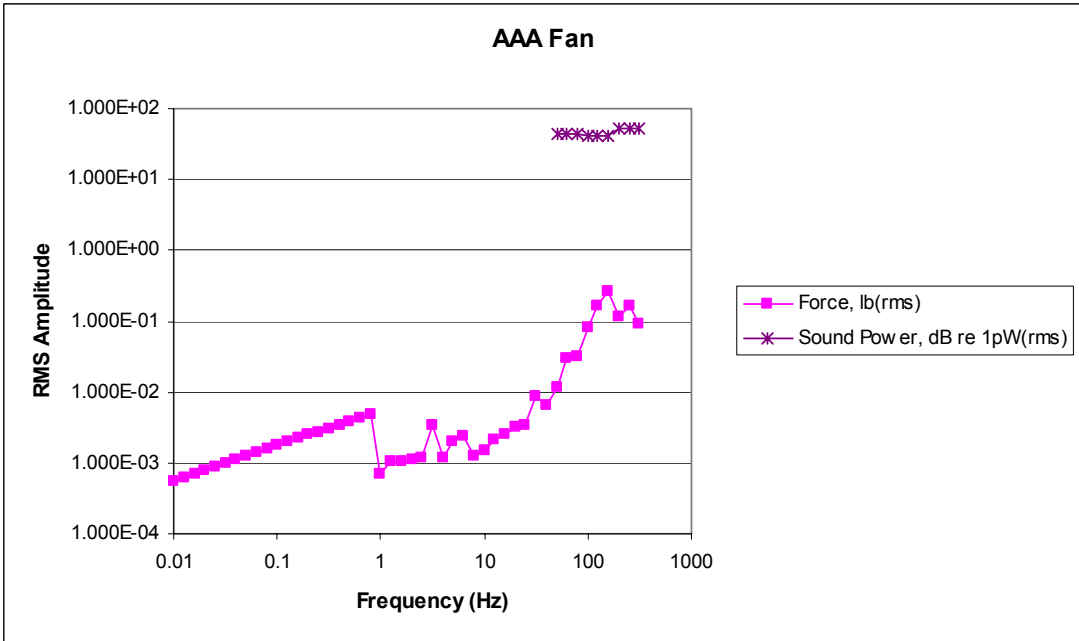

# Vibratory Analysis Forcing Functions - CMG

1/3-Octave Band Force Spectrum

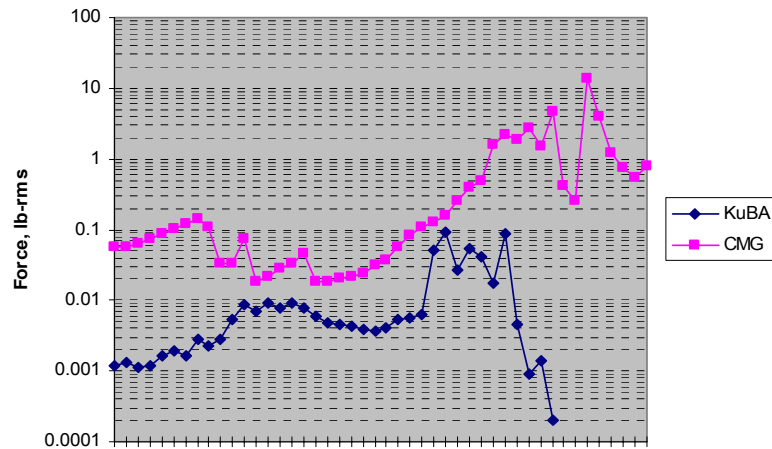

1/3-OCTAVE BAND MOMENT SPECTRUM

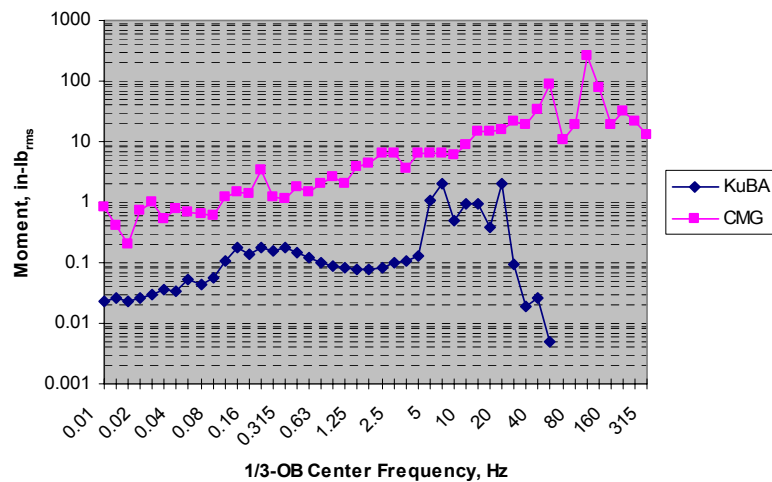

## Control Moment Gyros (CMG) For Torque Equilibrium Attitude

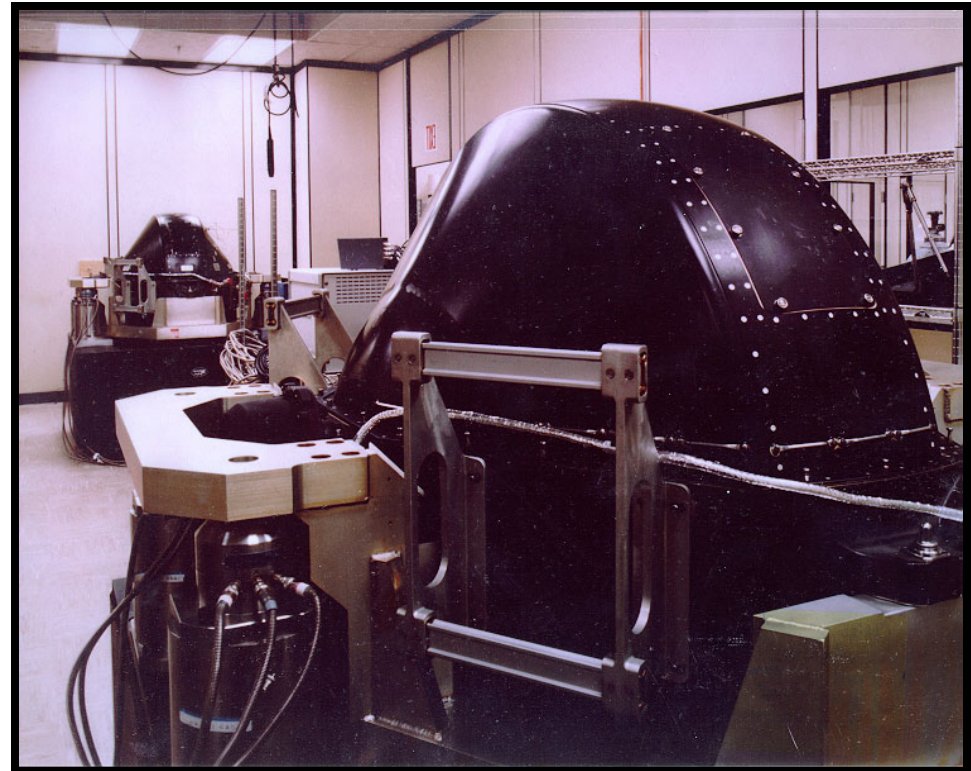

# Vibratory Analysis Forcing Functions - Articulate Joints

## Articulate Joints For PV Array Solar Incidence

**Solar and Radiator Rotary Joints: Torque Ripple, Bearing Friction, Gear Train Meshing Friction, Position/Resolver Error**



**SARJ Drive Motor  
In Test**

TRRJ 2 On-Orbit Acceleration from Encoder for Various Drives, Temperatures, Directions (Engaged/1.35 dpm)

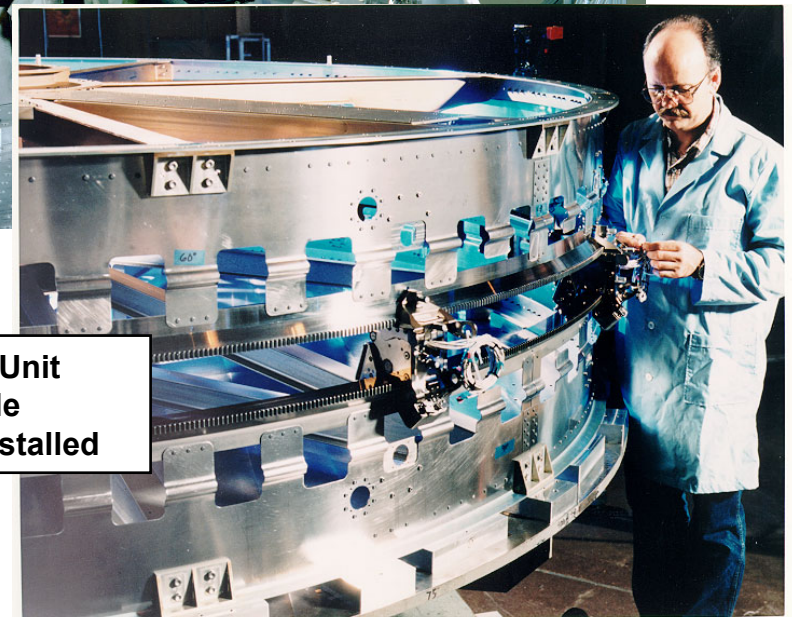
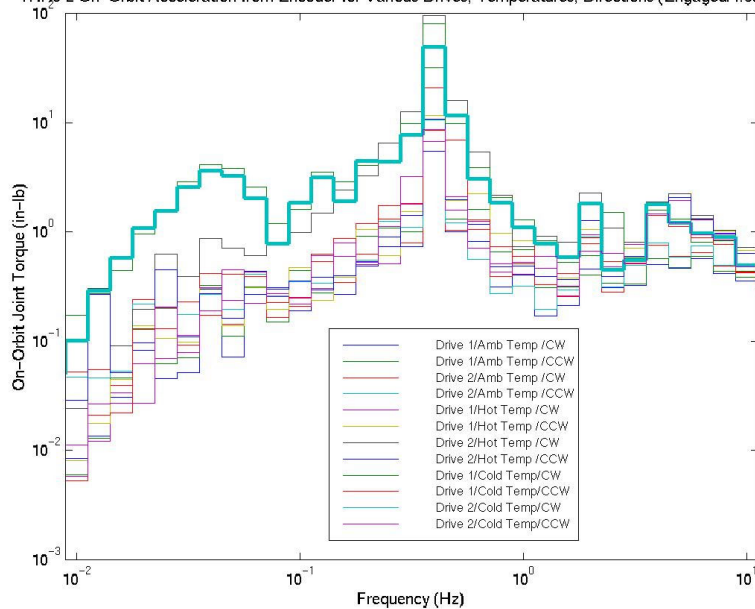

**SARJ Qual Unit  
With Trundle  
Bearings Installed**

March 6, 2003

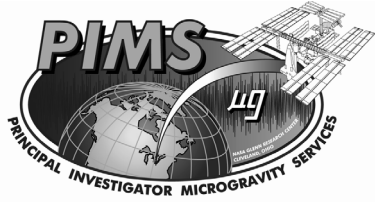

## Vibratory Analysis Forcing Functions - Exercise Devices



### Treadmill

- SM treadmill disturbance definition based on horizontal test measurements for TVIS certification.
- Measurements include source isolation effects
- Force measurements from 3 cases were used as inputs for transient analysis.
  - speed 1.9, 4.2, and 8.1 m/h

### Cycle Ergometer

- US Lab ergometer disturbance definition based on test measurements for CEVIS certification.
- Measurements include source isolation effects
- Force measurements from 4 cases were used as inputs for the transient analysis.
  - 190 lb. cycling 60, 75, 90, and 105 rpm
- Ergometer mounted on rack seat-tracks in US Lab. Possible relocation to Node 1.

# Vibratory Analysis Forcing Functions - Exercise Devices

TVIS Certification Test

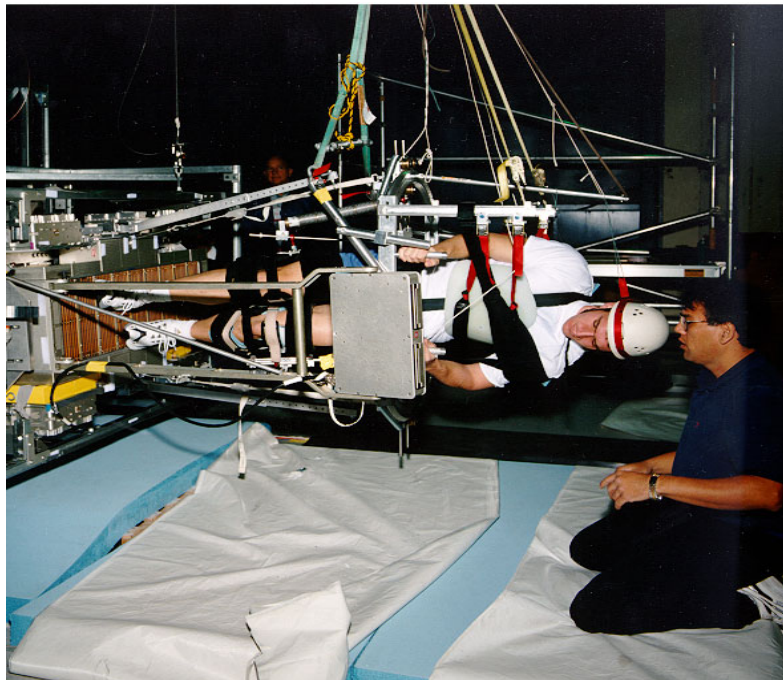

6 DOF Transient Force/Moment For Various Subjects

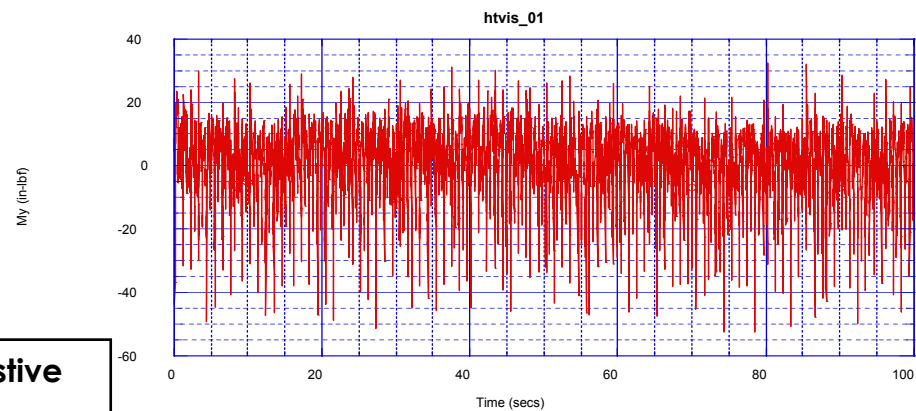
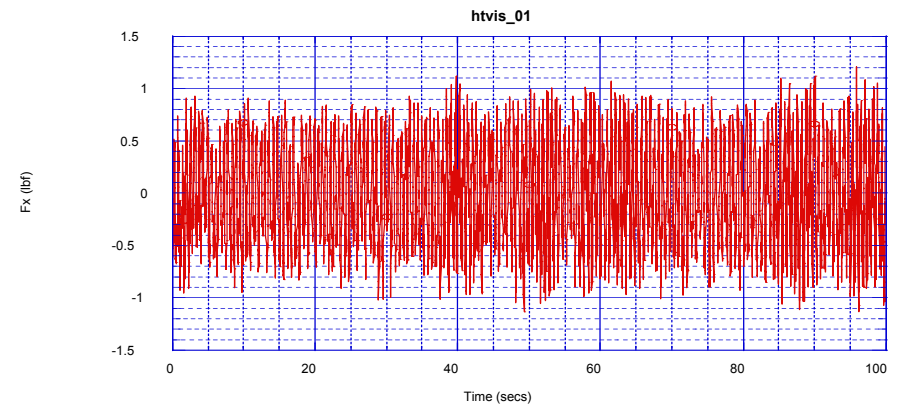

**Crew Exercise Equipment:** Treadmill, Ergometer, Resistive Exercise Device (Isolated/Non-isolated)

**InterVehicular Activity:** Translation, Station Keeping, Console Operations, ... Scheduled Maintenance.

# Vibratory Analysis Forcing Functions

## RS Service Module Element Ground Test

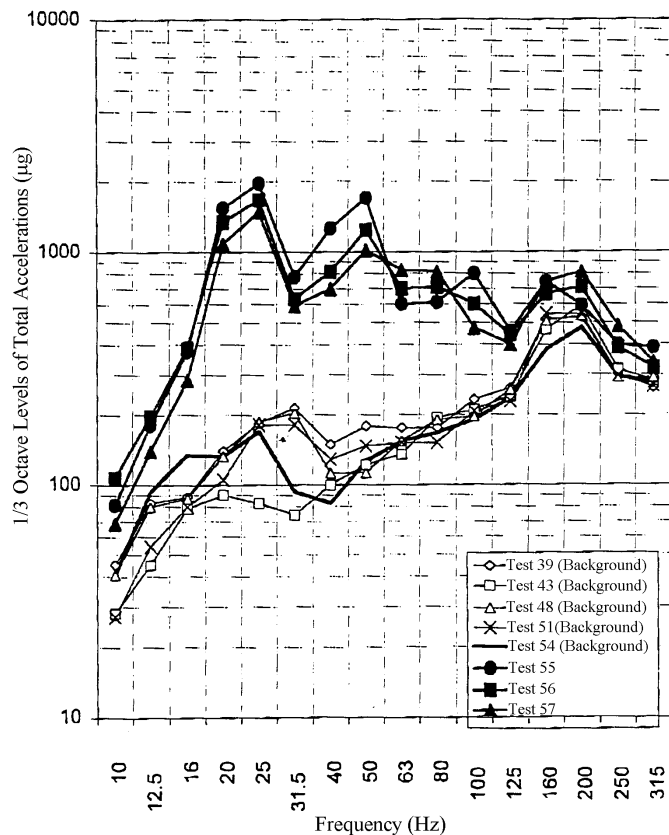

## ESA Columbus Module Component Ground Test

ECLSS : -

- \* one Cabin fan assy (CFA EM5) (test data eq. & sect.)
- \* one Cabin fan assy as IMV Supply fan (test data eq. & sect.)
- \* one Cabin fan Assy as IMV Return Fan (test data - eq. & sect.)
- \* two Condensate Water Separator Assies (CWSA EM) (test data - eq. & sect.)
- \* one Condensate Heat Exchanger/Thermal Control valve (CHX/TCV) (test data - eq. & sect.)
- \* TWO WASTE GAS Line shut Off Valve (LSOV) (test data -eq.)
- \* One WLSV EM (test data - eq.)
- \* Two PPO2 (test data -eq.)
- \* Airbox (Test data-Section)

TCS:

- \* one WPA (test data -eq.)
- \* one WOO (actuated) (test data -eq.)
- \* two WTMO (actuated) (test data - eq.)
- \* fluxed ducting (test data - sect.)

Structural Stick/slip :

- \* Stick/slip at MDPS/bracket interface (analytical evaluation)

## NASDA ICS Antenna Slew & Tracking

# Vibratory Analysis Rack

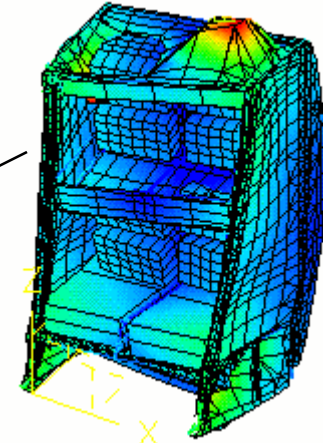
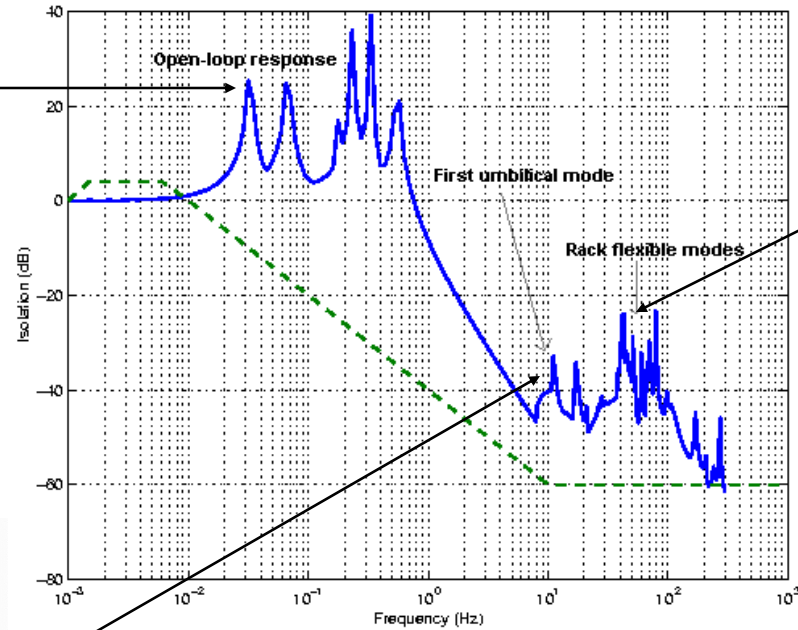
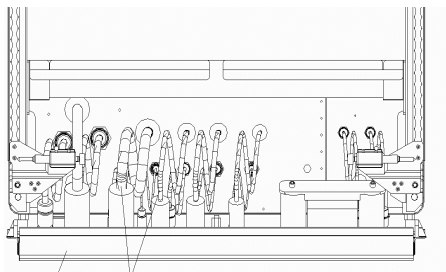
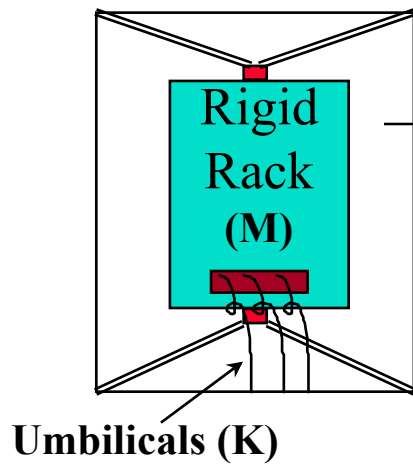

- Resonances between 0.01-1 Hz are rigid rack-umbilical modes (M-K)
- Resonance around 10 Hz is the umbilical loop resonance
- Resonances above 26 Hz are due to rack flexible modes being excited by umbilical and pushrod resonances.

# Vibratory Results DAC 9 - Composite

DAC-9 Microgravity Environment Prediction (with PIDS level ARIS)

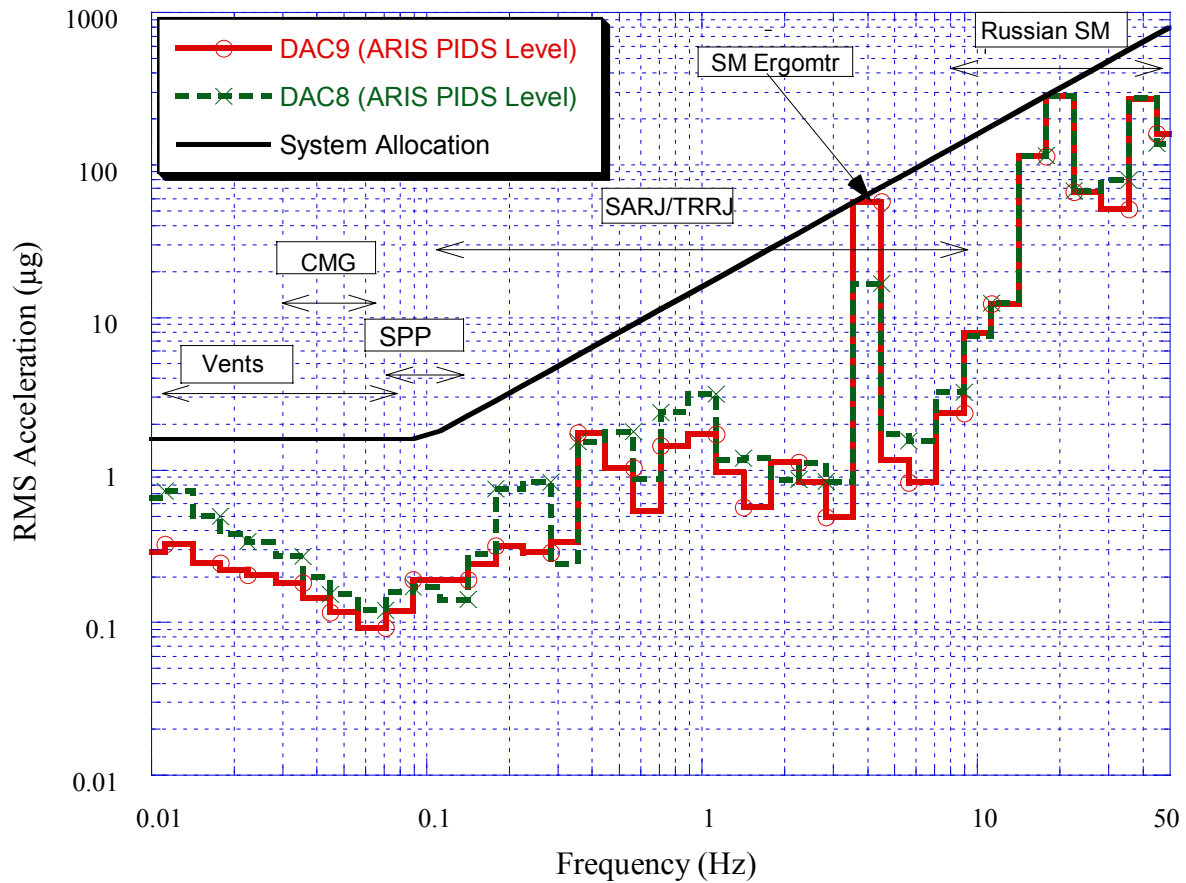



# Vibratory Results DAC 9 – Composite

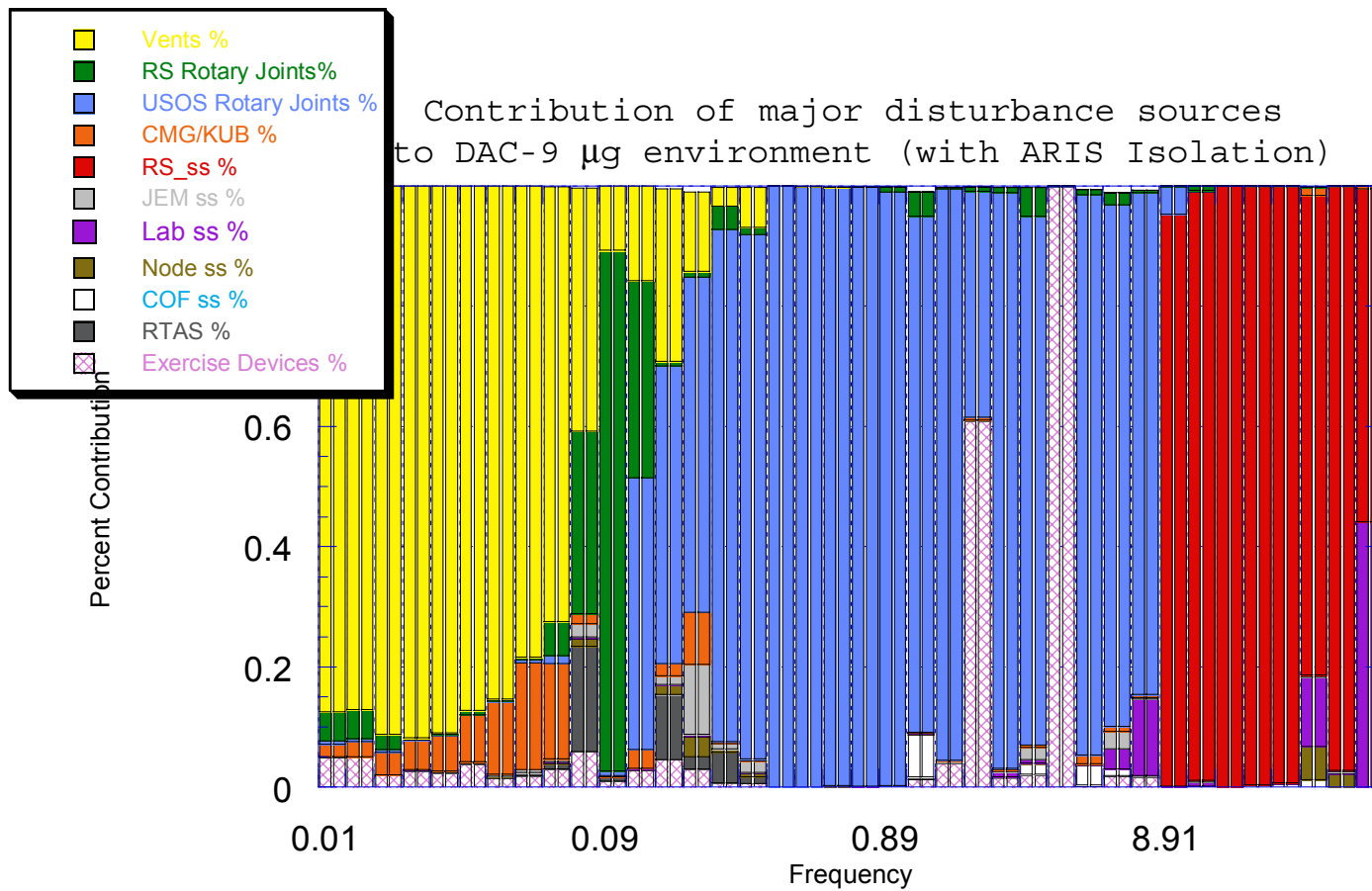

# Vibratory Results DAC 9 – ARIS

## Microgravity Environment Performance (ARIS PIDS)

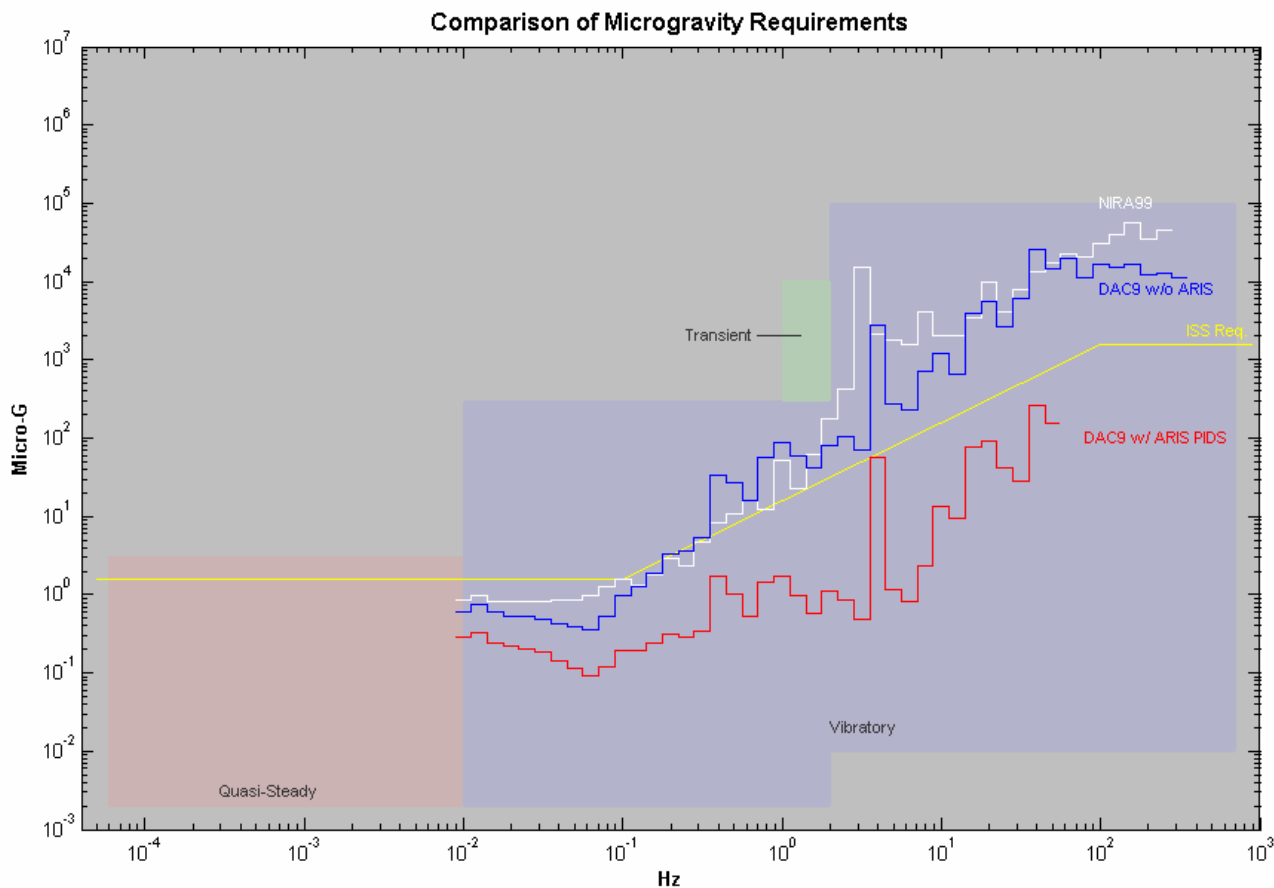

# Vibratory Results DAC 9 - ARIS

DAC-9 Environment: Effect of ARIS performance

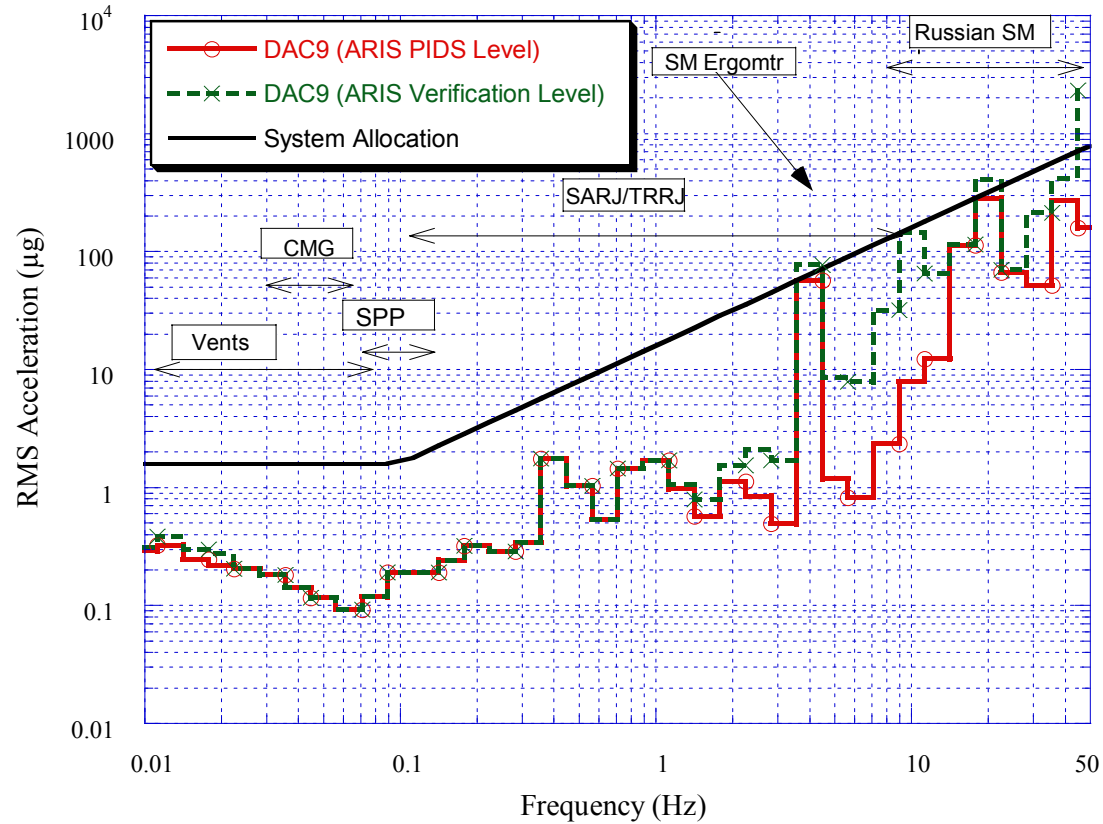

# Vibratory Results DAC 9 – Composite, Venting

DAC-9 Microgravity Environment Prediction (with PIDS level ARIS)  
Effect of ESA Vent Disturbance Definition

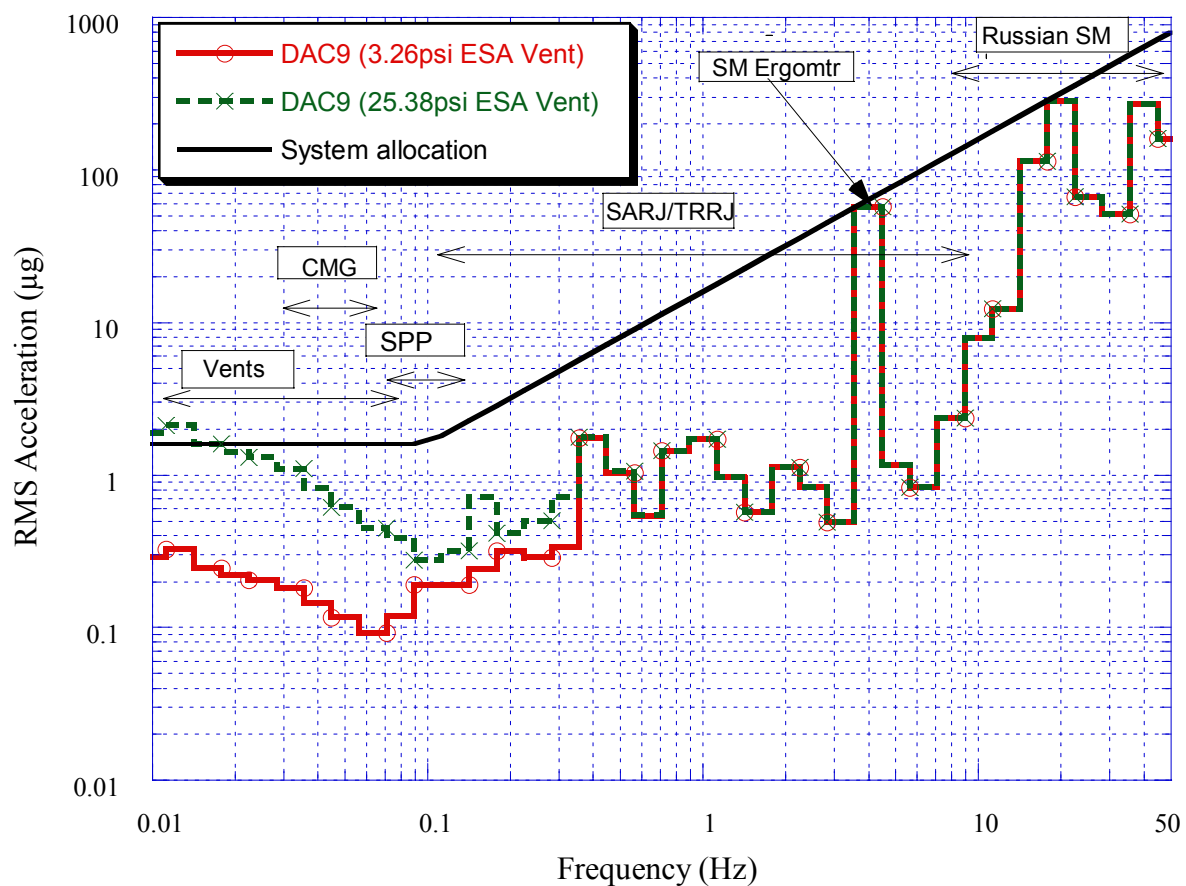

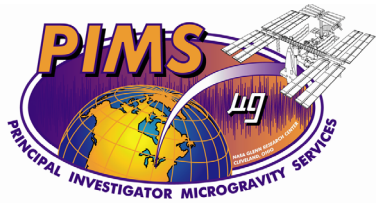

# Vibratory Results DAC 9 – USOS



### DAC-9 Environment: USOS Disturbance

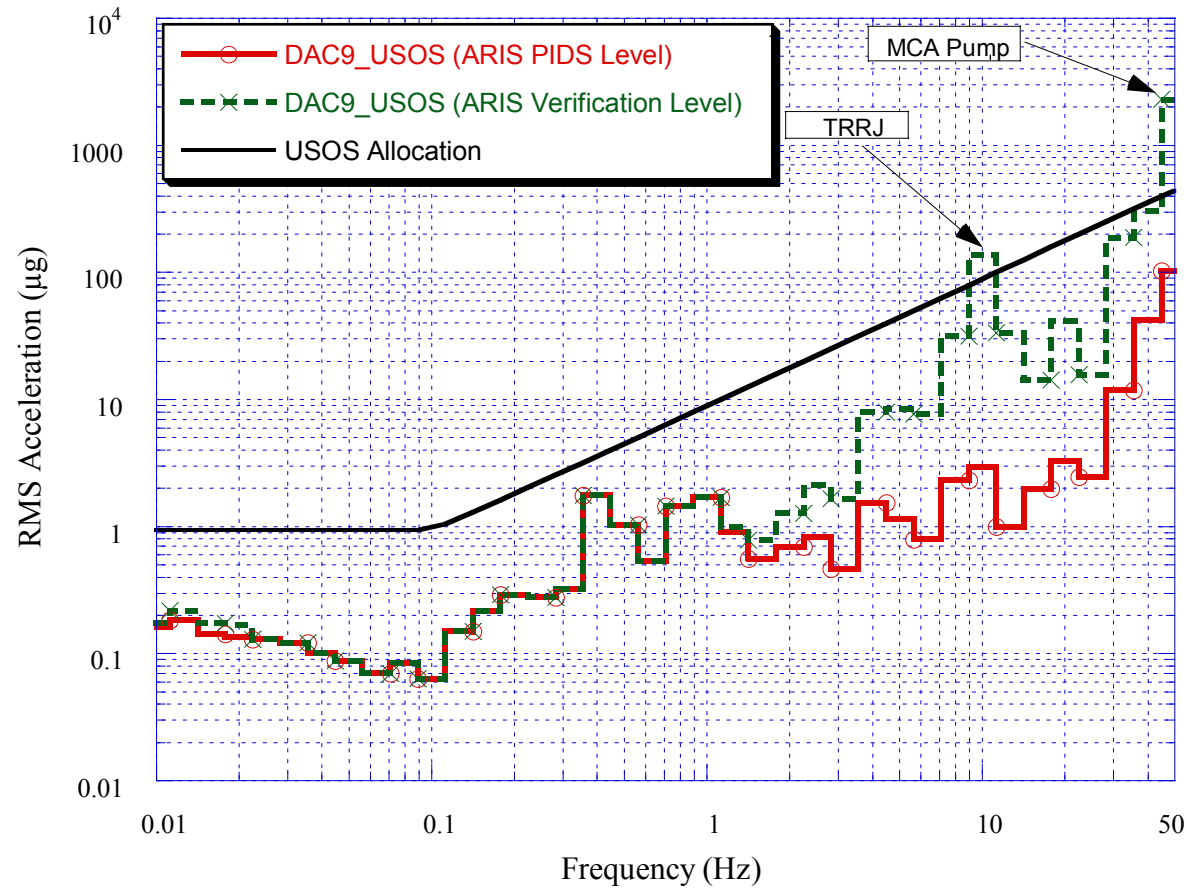

# Vibratory Results DAC 9 – JEM

## DAC-9 Environment: JEM Disturbance

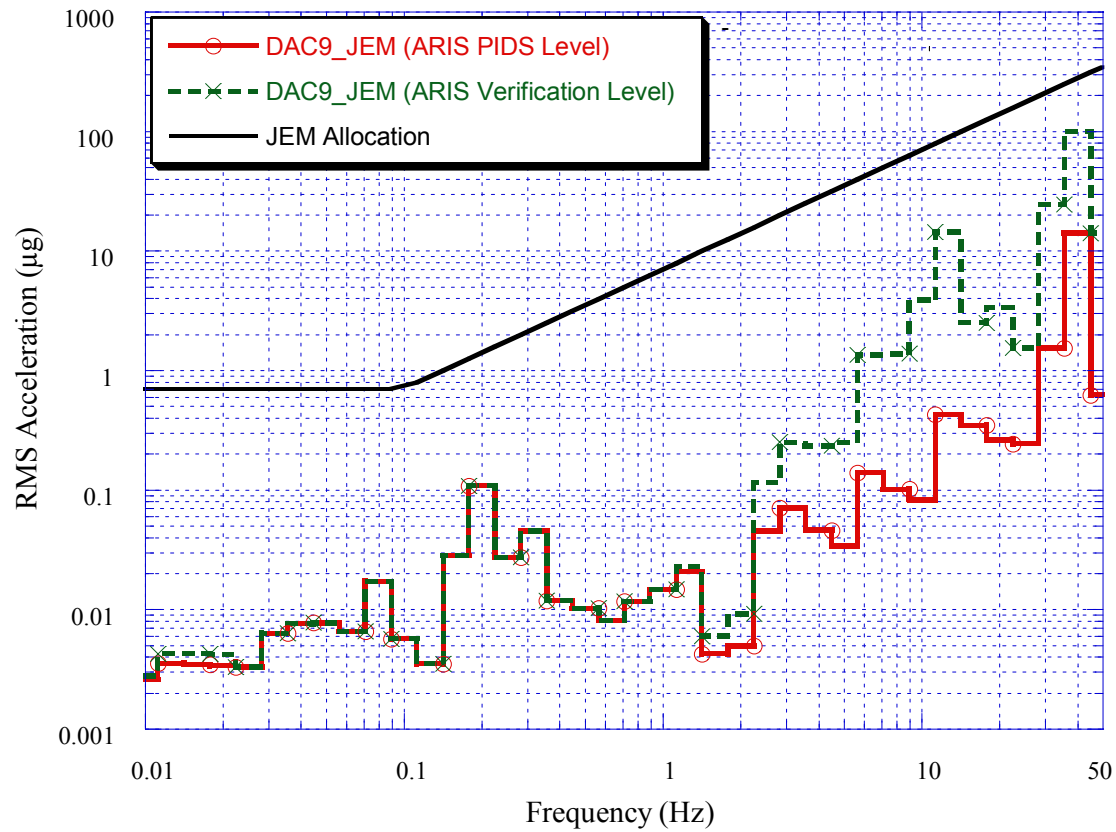

# Vibratory Results DAC 9 – ESA

## DAC-9 Environment: ESA Disturbance

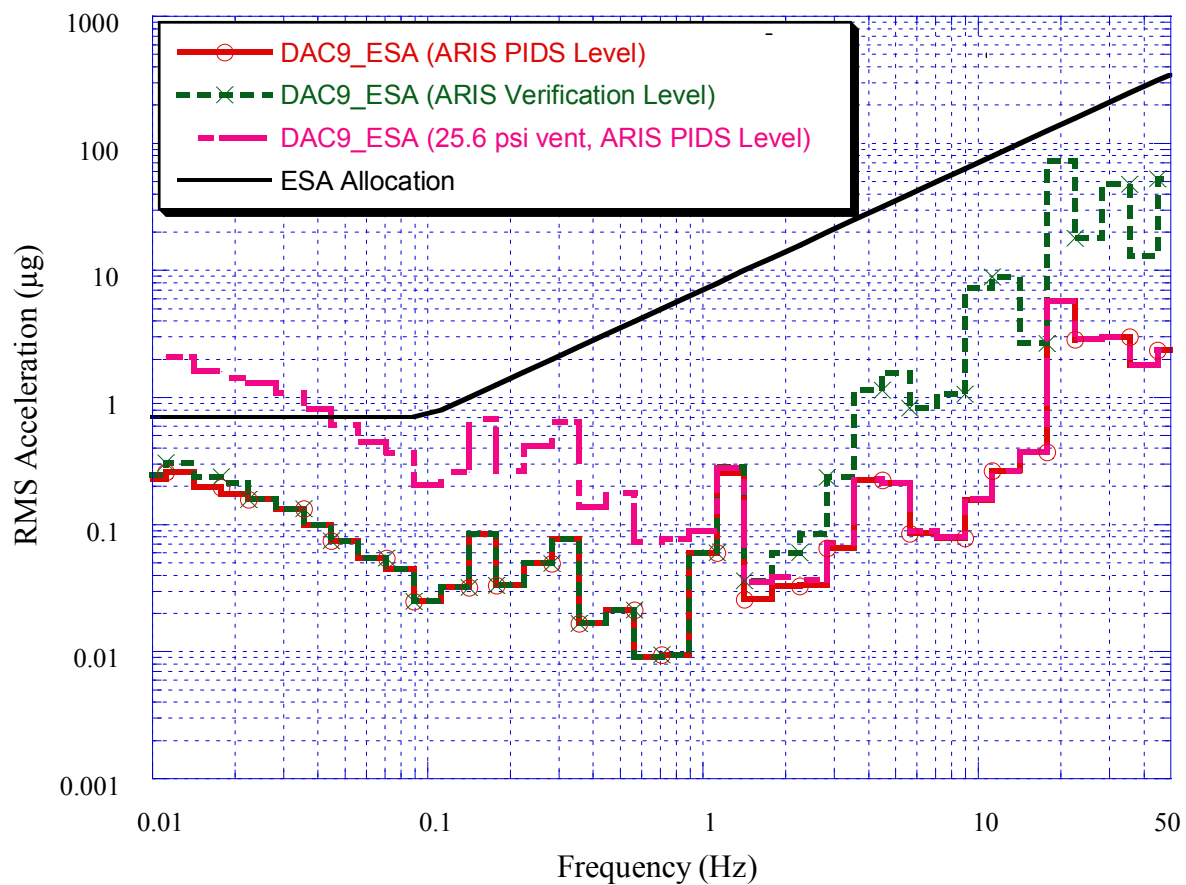

# Vibratory Results DAC 9 – RS

## DAC-9 Environment: RS Disturbance

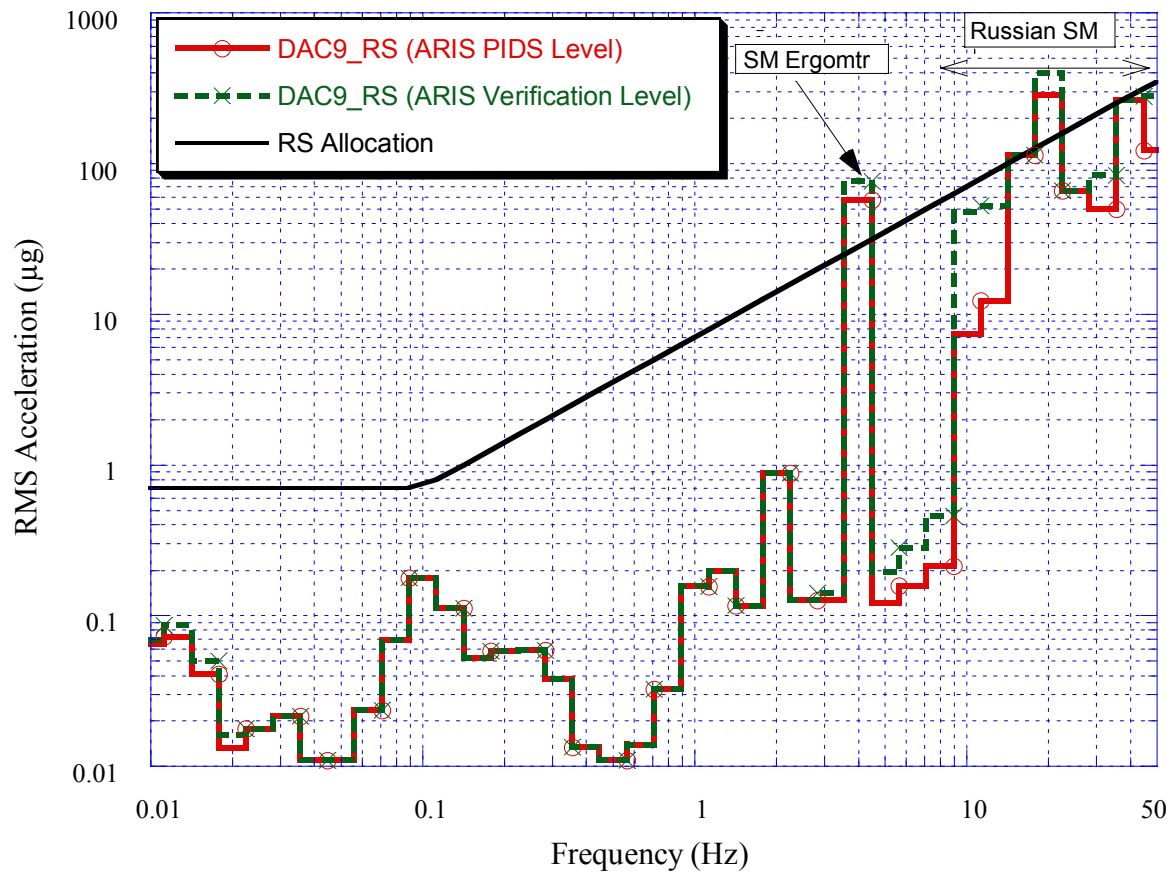



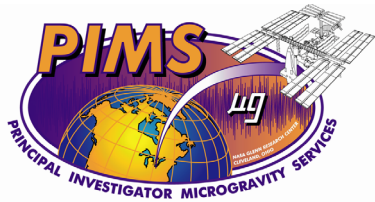

## Vibratory Results NIRA 99 - US Lab



### Non-Isolated Rack Assessment Differences From DAC9 Requirement Compliance Results

- 1% Damping
- + 2Crew translations & 2console ops
- + Payload disturbances (8 racks in Lab, 3 in COF and 2 in JEM)(21 sources per rack includes AAA fan.)
- @ Non-isolated rack interfaces
- Non-isolated Lab ergometer - subsequently isolated

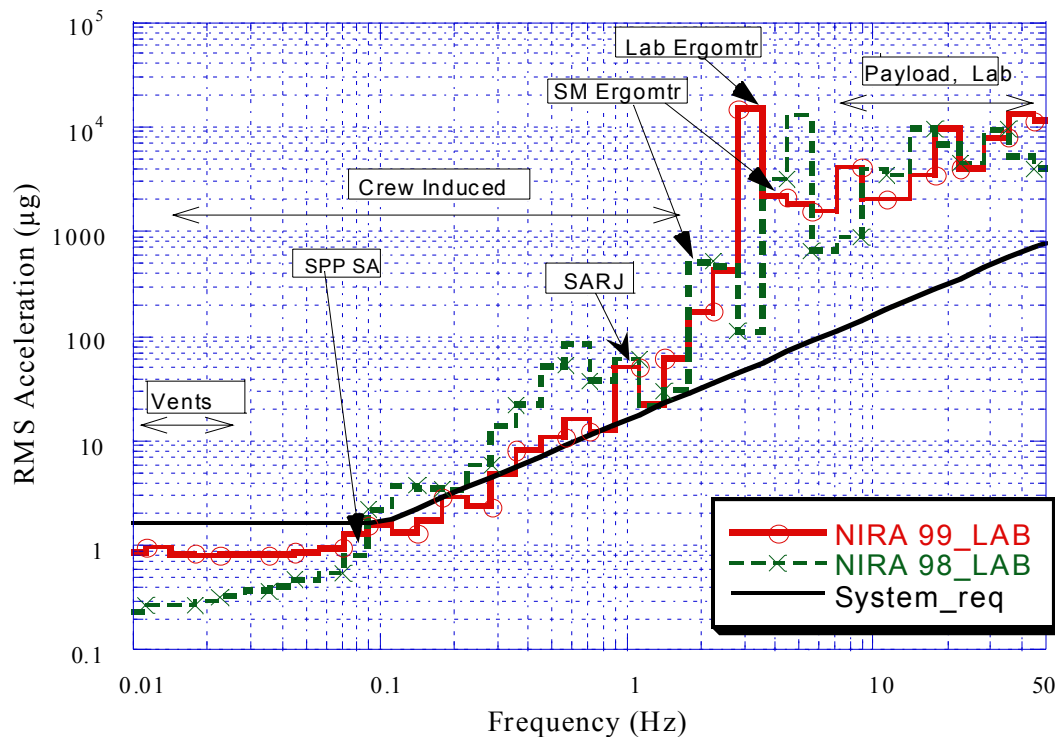

March 6, 2003

MEIT-2003 / Section 20 / Page 49

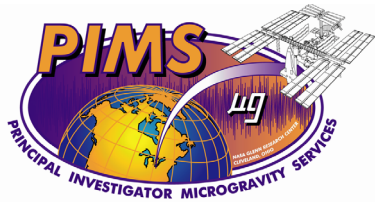

# Vibratory Results NIRA 99 - JEM-PM



## Non-Isolated Rack Assessment Differences From DAC9 Requirement Compliance Results

- 1% Damping
- + 2Crew translations & 2console ops
- + Payload disturbances (8 racks in Lab, 3 in COF and 2 in JEM)(21 sources per rack includes AAA fan.)
- @ Non-isolated rack interfaces
- Non-isolated Lab ergometer - subsequently isolated

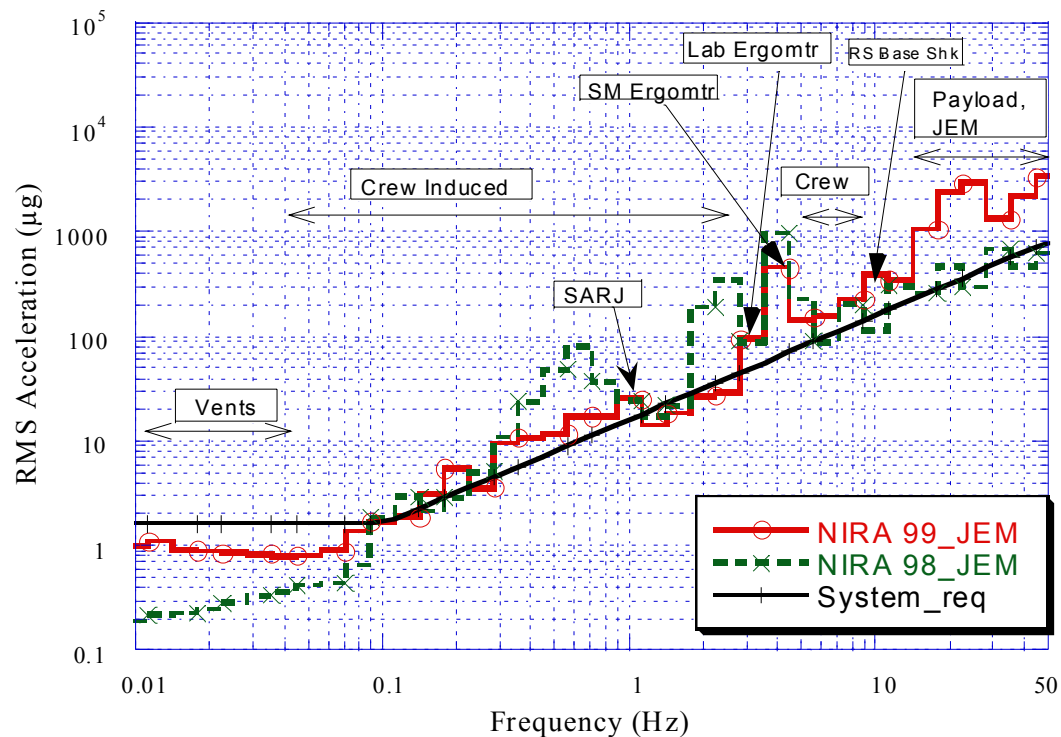

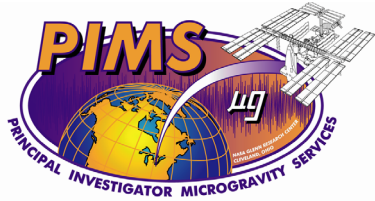

# Vibratory Results NIRA 99 - JEM-EF



## Non-Isolated Rack Assessment Differences From DAC9 Requirement Compliance Results

- 1% Damping
- + 2Crew translations & 2console ops
- + Payload disturbances (8 racks in Lab, 3 in COF and 2 in JEM)(21 sources per rack includes AAA fan.)
- @ Non-isolated rack interfaces
- Non-isolated Lab ergometer - subsequently isolated

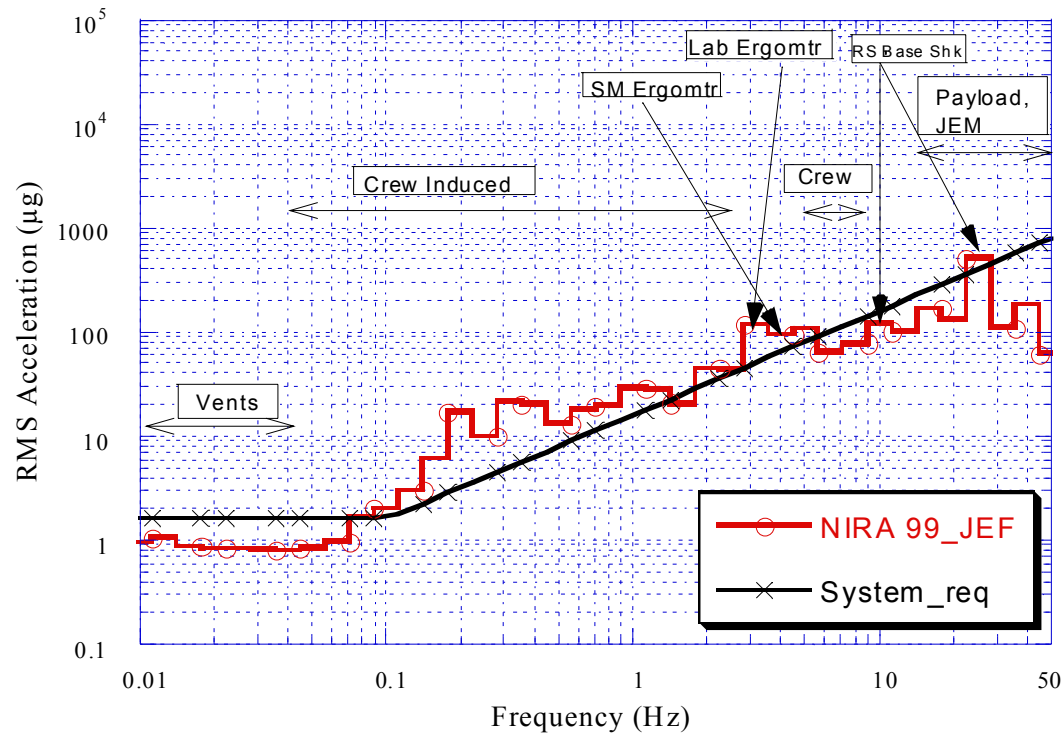

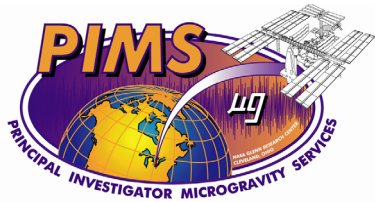

# Vibratory Results - NIRA 99 Non-Microgravity Mode (External Ops Case) U.S. Lab



## Non-Microgravity Mode Differences From NIRA-99

- Add non-microgravity mode disturbances to NIRA-99
- External Operations Case presented includes 2 EVA's, JEM Airlock and Mobile Transporter ops
- Other cases examined focused on thruster activity - reboost, CMG de-saturation, attitude hold
- Cases still to be examined: docking, berthing, rack rotation, et cetera

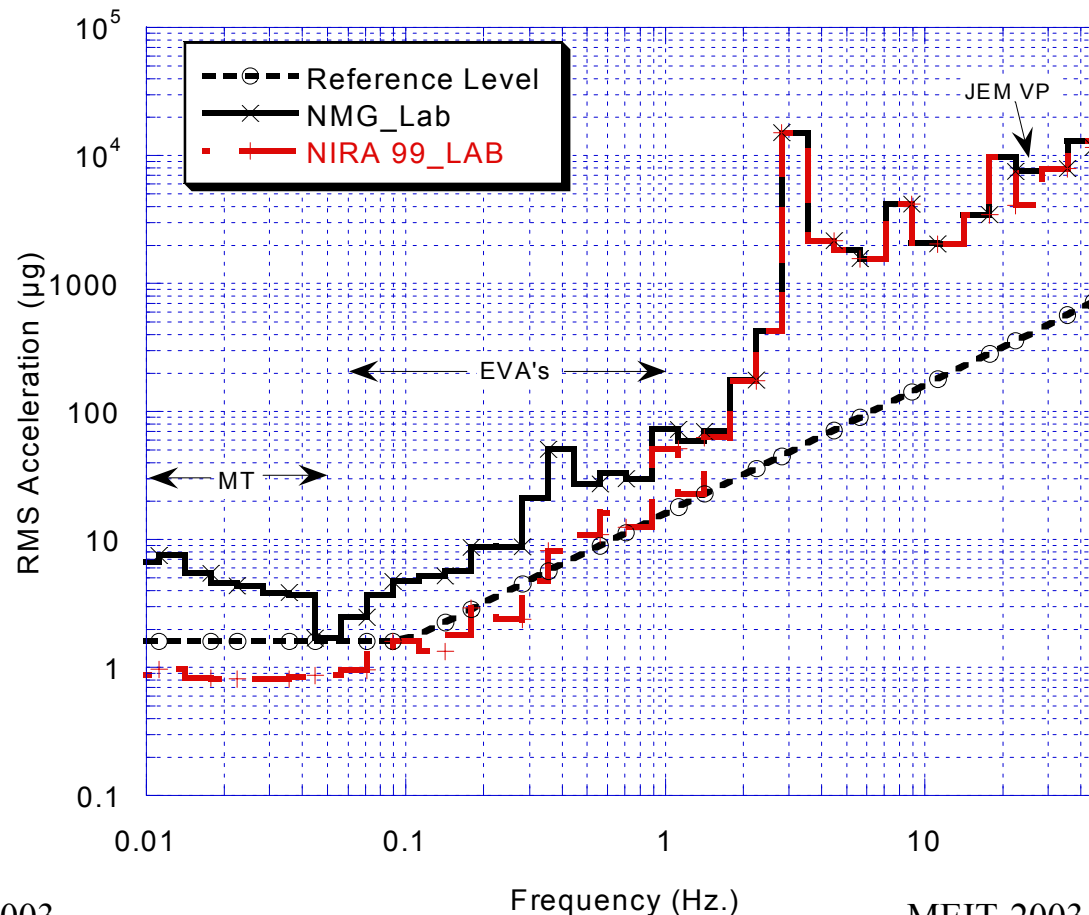

# VibroAcoustic Analysis Methods & Tools

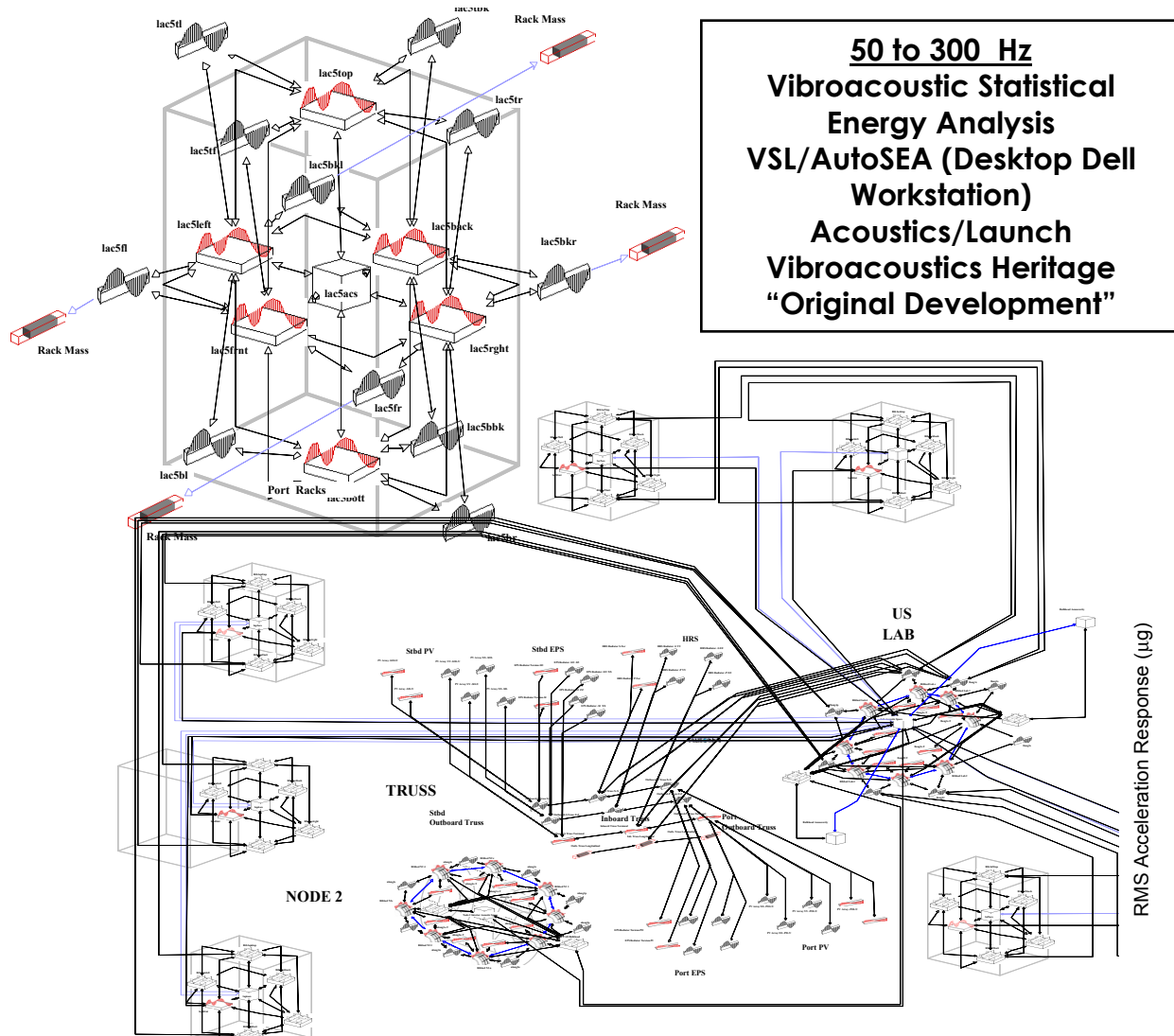

50 to 300 Hz  
**Vibroacoustic Statistical Energy Analysis**  
VSL/AutoSEA (Desktop Dell Workstation)  
Acoustics/Launch  
Vibroacoustics Heritage  
"Original Development"

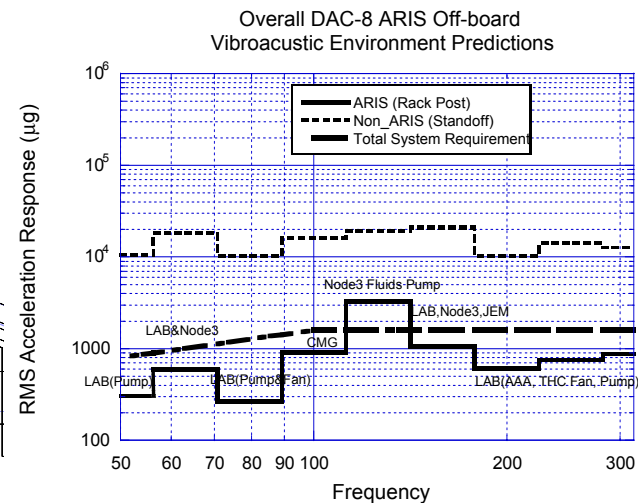
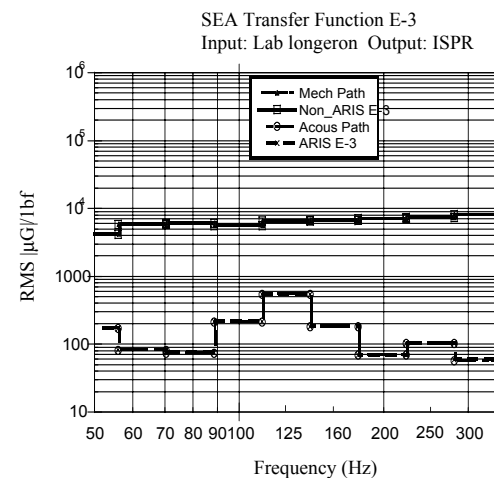

March 6, 2003

# Vibroacoustic Results

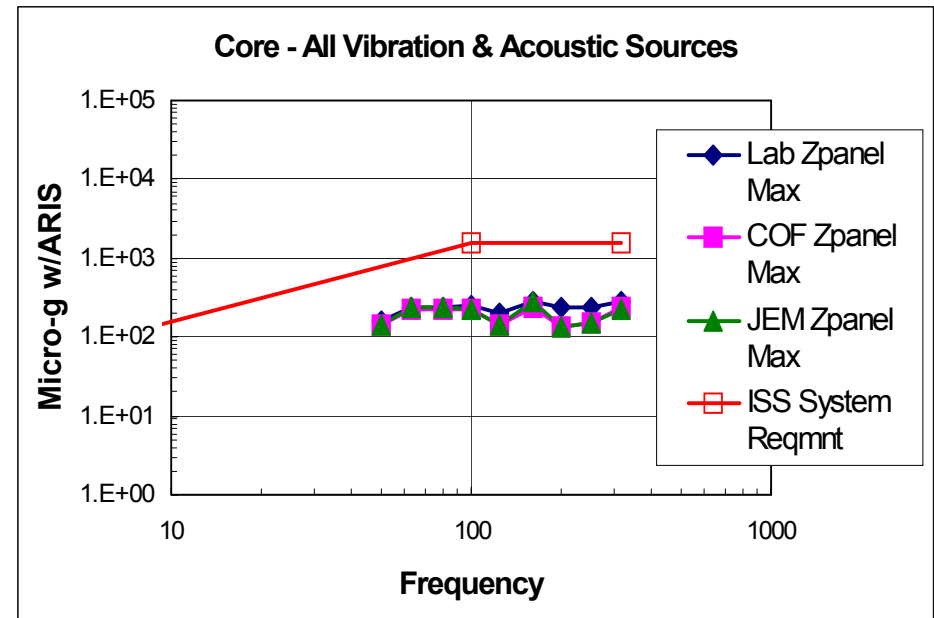
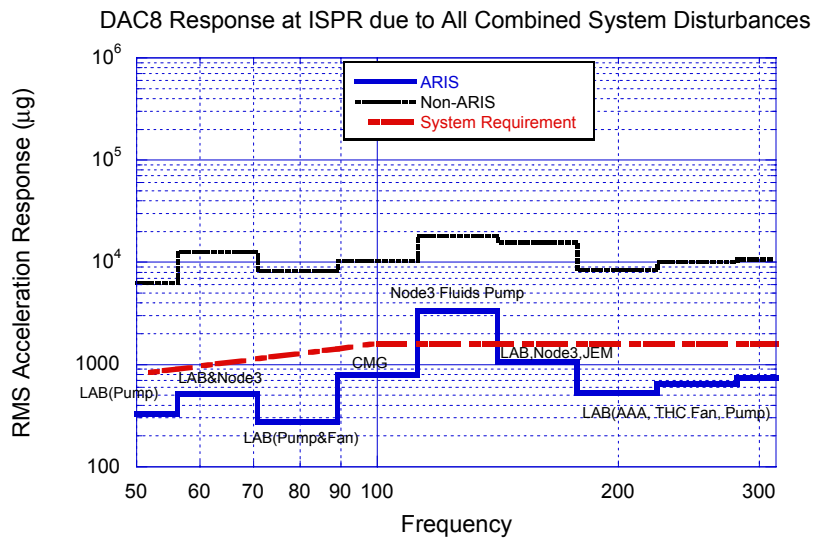

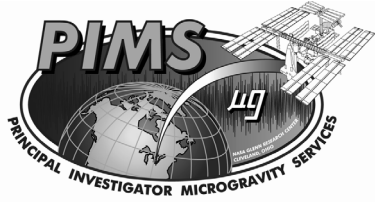

## Summary

---

- The ISS vehicle has been designed to provide researchers a viable microgravity environment established jointly with the science community.
  - **Features:**
    - Laboratories located near the vehicle center of mass
    - Articulating photovoltaic and radiator appendages to enable once per orbit vehicle rotation
    - Non-propulsive attitude control
    - Source isolated exercise equipment
    - Receiver isolation systems
    - Microgravity Mode operations

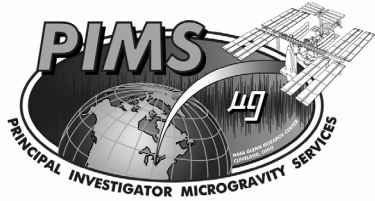

## Summary

- DAC-9 quasi steady predictions shows 14 of 32 rack locations meet  $1\mu\text{g}$  requirement.
- DAC-9 vibratory environment prediction is below the overall system allocation with standard ARIS attenuation (i.e.. PIDS requirement + margin). However, with the 25.6 psi exit pressure ESA vent disturbance will cause exceedance at low frequencies.
- When ARIS performance is accounted for there are exceedances due to the SM ergometer, SM a/c compressor and Lab pump harmonics.
  - Exception E-TDS V6A.1.3-06-1 processed for SM Ergometer/ARIS from Flt 6A to UF3. To be resolved by first obtaining on-orbit confirmation of both the acceleration environment and the ARIS isolation performance (ICE experiments), and then by determining the appropriate modifications and by their subsequent implementation.
  - Exception E-TDS V2.1.3-03,04 processed for non-compliance of the SM TCS compressor as identified by RSC-Energia based on the Service Module ground test results. To be resolved through design changes (longer flex hoses, soft rubber mounts), ground test validation and on-orbit installation.
  - Exceedances due to Lab pump harmonics addressed through refined analysis, VAC5A.
- All transients meet integrated 10-second transient requirements except ESA vent
  - 16 microg seconds for 3.26 psi exit pressure case
  - 130 microg seconds for 25.4 psi exit pressure case